



# Underwater Housing for Canon EOS M3

Product Number 6973.03

## **I n s t r u c t i o n   M a n u a l**

Thank you for your purchase of Ikelite equipment. Please read this instruction manual completely before attempting to operate or dive with this product. Please refer to the back page of this manual to register your Ikelite product.

## Table of Contents

<b>PREPARATION</b> .....	P. 3
<b>SPECIFICATIONS - no camera installed</b> .....	P. 4
<b>INCLUDED in the BOX</b> .....	P. 4
Parts of the Housing - Front View .....	P. 5
Parts of the Housing - Back View .....	P. 6
<b>HOUSING and CAMERA SETUP STEPS</b> .....	P. 7
STEP 1 - Attach/Remove Tray and Handle .....	P. 7
STEP 2 - Initial Camera Settings .....	P. 8 - 9
STEP 3 - Opening the Housing .....	P. 9
STEP 4 - Install Camera/Hotshoe in Housing .....	P. 9 - 11
STEP 5 - Closing the Housing .....	P. 12
STEP 6 - Attach Optional Mirrorless Lens Ports .....	P. 12
STEP 7 - Final Check.....	P. 13
<b>USAGE</b> .....	P. 13
Entering the Water .....	P. 13
Removing the Camera from the Housing.....	P. 14
<b>STROBE USE and COMPATIBILITY</b> .....	P. 15
Strobe Compatibility .....	P. 15
Ikelite Housing Conversion Circuitry .....	P. 15
Attach Ikelite Sync Cord to the Housing and Strobe .....	P. 15 - 16
Attach Ikelite Strobe Arm to the Housing Handle.....	P. 17
<b>SPARE PARTS</b> .....	P. 18
<b>RECOMMENDED ACCESSORIES</b> .....	P. 18
<b>MAINTENANCE</b> .....	P. 19 - 24

## Table of Contents - continued

PHOTO TIPS .....	P. 25
TROUBLESHOOTING .....	P. 26 - 28
CUSTOMER SUPPORT.....	P. 29
LIMITED WARRANTY .....	P. 30
RETURNING PRODUCTS FOR SERVICE .....	P. 31
PRODUCT REGISTRATION .....	Back Page

## PREPARATION

This product has been water pressure tested at the factory and is depth rated to 200 ft (60 m). Thoroughly inspect and immerse the empty housing completely in water before installing a camera. If any fogging occurs or droplets of water enter the housing, do not install a camera. Clean the main housing o-ring and retest to make sure that the housing is watertight. Refer to the Troubleshooting section, **page 26**.

Please read your camera manual thoroughly to have a full understanding of each camera function.

If you are new to underwater photography, be sure to read the Photo Tips section, **page 25**.

## SPECIFICATIONS - no camera installed

<b>Controls</b>	.....All camera buttons and dials are accessible
<b>Buoyancy</b>	.....Slightly negative in freshwater
<b>Depth Rating</b>	.....200 ft (60 m)
<b>Strobe Connection</b>	.....Ikelite Digital TTL ICS-5 5-pin Electrical .....Bulkhead plus TTL circuitry compatible with .....current model Ikelite DS-series strobes
<b>Use Built-in Flash</b>	.....Yes, with Fiber Optic Ports only
<b>Tray and Handle Weight</b>	.....8.7 oz (247 g)
<b>Main O-Ring</b>	.....0110
<b>Housing Dimensions</b>	.....6.4 x 7.6 x 5.3 in (16 x 19 x 13.5 cm)
<b>Housing Weight</b>	.....3.1 lb (1.4 kg) not including tray, handles or .....lens port
<b>Housing Material</b>	.....Polycarbonate front, acrylic back

## INCLUDED in the BOX





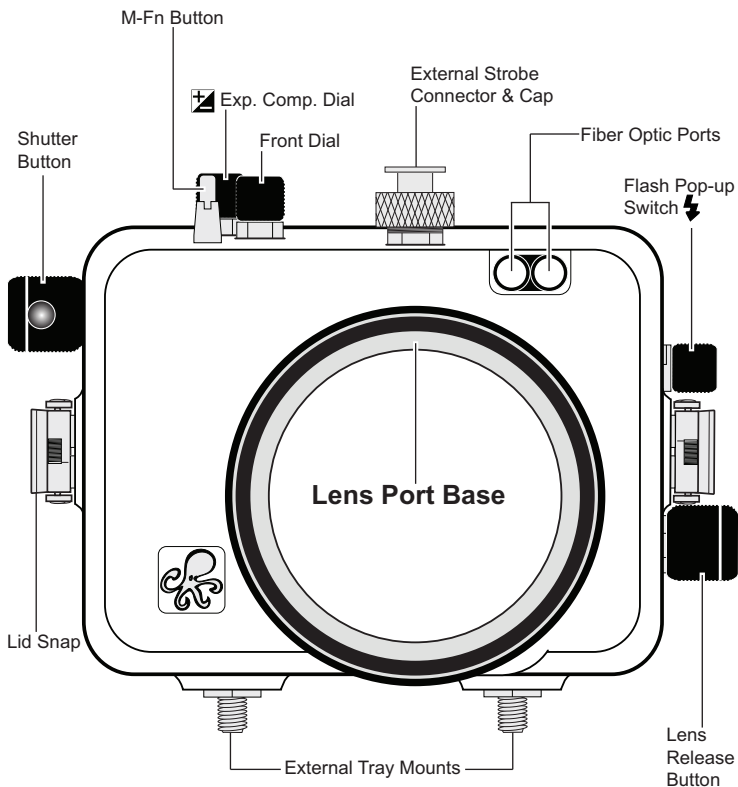

- Housing
- Instruction Manual
- Tray with Quick Release Handle
- Waterproof Bulkhead Cap (*connected to external strobe connector*)
- Silicone 1cc Lubricant Tube
- Accessory Package (includes cleaning cloth and additional control tips).

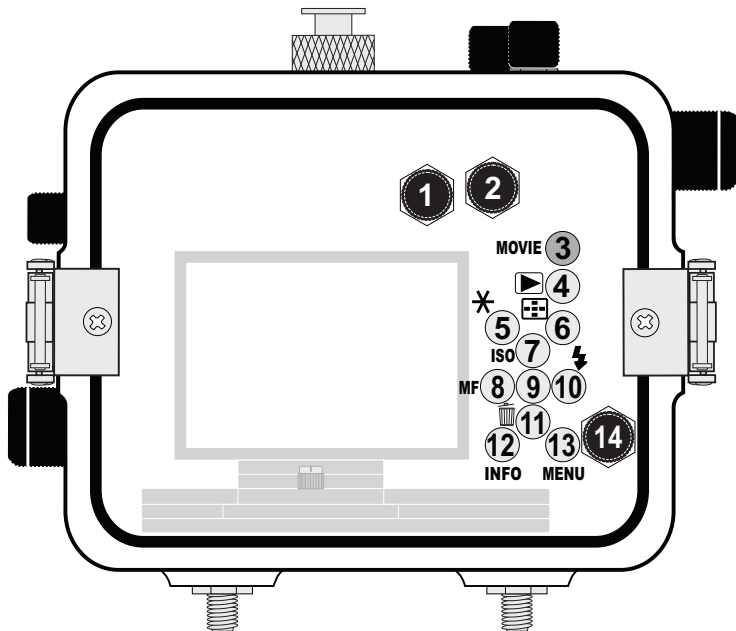
## Parts of the Housing - Front View



## Parts of the Housing - Back View



1. Mode Dial
2. Power Button
3. Movie Button
4.  Playback Button
5.  AE Lock Button
6.  AF Frame Adjustment
7.  ISO/UP Button
8.  MF/LEFT Button
9. Quick Setting Menu/**SET** Button
10.  Flash/RIGHT Button
11.  Erase/DOWN Button
12. **INFO** Information Button
13. **MENU** Button
14. Control Dial

## HOUSING and CAMERA SETUP STEPS

### STEP 1 - Attach/Remove Tray and Handle

*Skip STEP 1 if Tray and Spacer are factory installed.*

One side of the Spacer has an adhesive backing. Remove the Protective Film to adhere the Spacer to the Tray.

Using a 9/16" open/box end or socket Wrench (*not supplied*), firmly tighten the External Tray and Spacer to the Mounting Bolts using the two 3/8-16 Nuts and Washers supplied in the accessory package. Reverse procedure to remove. **Note:** Tray and Handle may be attached before or after the camera is secured in the Housing. We recommend attaching them immediately to avoid scratching table tops with the Mounting Bolts.

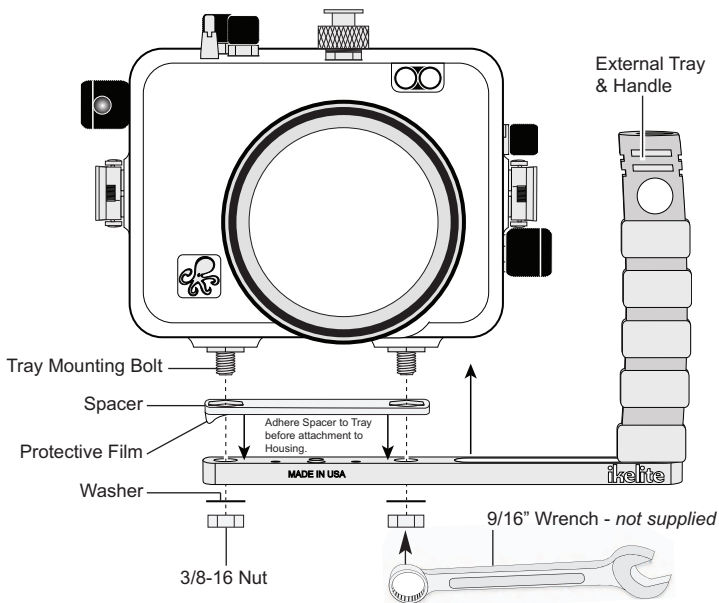

## STEP 2 - Initial Camera Settings - before placing camera in housing

Setup your camera for underwater use and then adjust your settings once underwater.

- Insert a fully charged camera battery and a SD card.
- Set Mode Dial to “M” Manual Mode. Set Aperture to f/8 and shutter speed to 1/125th second. Other shooting modes are not recommended.

### - In Menu:

Set Image Quality to “L” 24M and Still Image Aspect Ratio to “3:2.”

Set Image Review to “8 sec” and Touch Shutter to “Disable.”

Set AF operation to “ONE SHOT” and AF method to “1-point AF.”

Set AF + MF to “Off” and IS Settings to “Continuous, Dynamic IS 2.”

Set Lens Chromatic aberration and Peripheral illumination to “Enable.”

Set ISO speed to “200” and Highlight tone priority to “Off.”

Set Auto Lighting Optimizer to “Standard.”

Set Metering mode to “Center-weighted avg.” 

### In Flash Control:

Set Flash firing to “” and E-TTL II meter to “Evaluative.”

Set Red-eye reduc. to “Off”

Set Built-in flash settings Flash Mode to E-TTL II and Shutter Sync. to “1st curtain.”

Set External flash settings as desired once a strobe is detected and turned on.

Set Movie rec. size to “FHD” and AF w/shutter button during  to “ON.”

### - In Menu:

Insert and format an SD card.  CAUTION: Save existing photos on a separate storage device before formatting.

Set ECO Mode to “Off.”

In Power Saving, set Auto Power Down to and Display Off to “Off.”

Set Touch Operation to “Disable.”

### - In Q.SET Menu:

Set White Balance to “Auto.” Always use auto white balance (AWB) > >



## STEP 2 - Initial Camera Settings - continued

when using a strobe/flash. When recording video or shooting stills without a strobe, AWB can still be used, but for more accurate and consistent colors we recommend setting Custom white balance .

- \* *All other camera functions not mentioned should be set to the user's preference.*

## STEP 3 - Opening the Housing

Lid Snaps have a **Lock**.

1. Push Lid Snap Locks forward and lift as shown. Open opposing Lid Snaps simultaneously. Keep pressure on the Lid Snaps so they do not fly open quickly. Some Lid Snaps have a lot of spring tension once they go over center, so keep a firm grip on each Lid Snap. Lid Snaps may also be opened one at a time.
2. Remove the Housing Back.

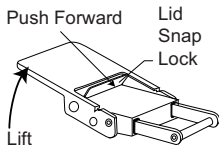

## STEP 4 - Install Camera/Hotshoe in Housing

1. Make sure the camera battery is fully charged and a SD card is inserted into the camera.
2. Rotate Housing Lens Release Button control up and forward against front of housing. Pull top housing control knobs up for more clearance.
3. The Mounting Plate is secured to the inside bottom of the housing. The camera Mounting Tray slides into the Mounting Plate. Use your index finger and thumb to pull the Thumb Screw and Tray away from the Mounting Plate, **Diagram A, page 10**. Use your other thumb to apply opposite pressure against the bottom of the housing to assist in removal of the Tray if necessary.

## STEP 4 - Install Camera/Hotshoe in Housing - continued

**Diagram A**

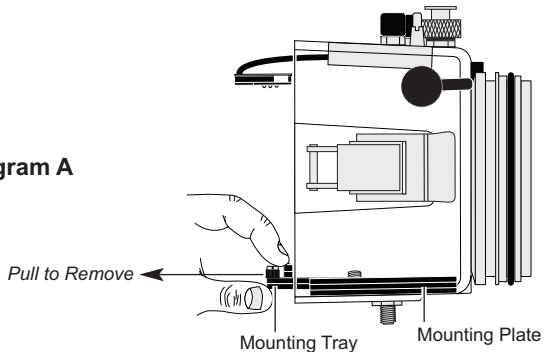

- Using a coin or flathead screwdriver (preferred), secure the camera Mounting Tray to the camera tripod mount, **Diagram B**. Tighten camera **firmly** to avoid movement on tray. The Mounting Tray only attaches one way with the

Thumb Screw to the back of the camera. An additional 1/4-20-inch tray hole allows attachment to a land tripod stand.

**Diagram B**

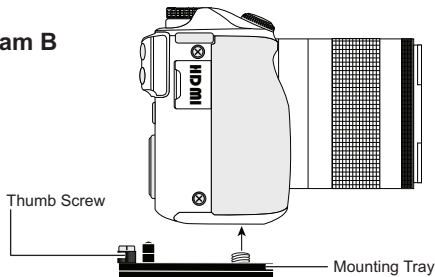

- Gently slide the camera with Mounting Tray back into the Mounting Plate, **Diagram C, page 11**. Using your thumbs, push against the Mounting Tray until it stops sliding forward into the Mounting Plate. Give the Tray an extra push to make sure it is properly seated all the way forward in the Mounting Plate and no housing controls are in the way.

## STEP 4 - Install Camera/Hotshoe in Housing - continued

- Slide the Hotshoe into the top camera mount until it stops. Hotshoe must be all the way forward in the camera mount to assure a good electrical connection with a strobe, **Diagram C, below**.  
Make sure hotshoe cord does not interfere with controls or the housing back when closing the housing.
- When using the Fiber Optic Ports, RAISE the camera flash. Make sure the flash is pointing forward before closing the housing.

Diagram C

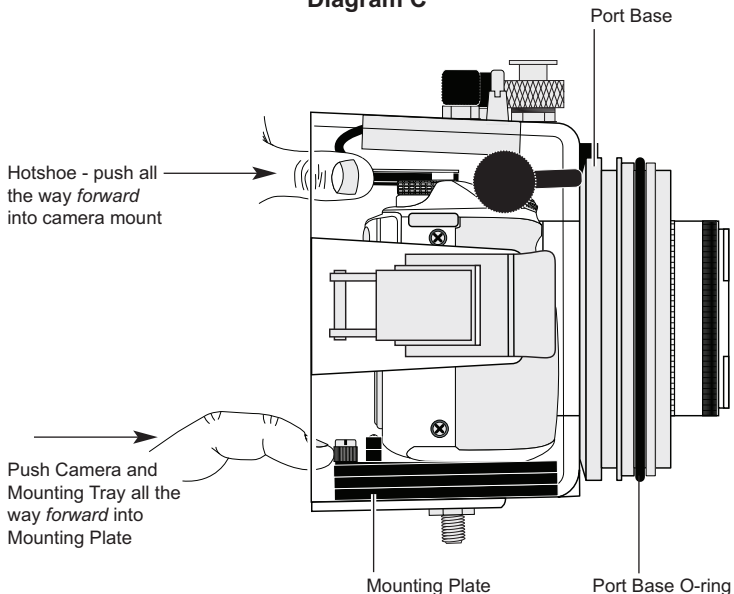

## STEP 5 - Closing the Housing

1. Place housing face down in your lap. Check to see that there is an o-ring on the housing back, and that it is clean and in its proper location.
2. Guide the back onto the housing front. Make sure the hotshoe wire is out of the way. Once the back is properly installed, the o-ring should touch the housing all the way around. There should be an even gap on each side of the housing between the housing and the back.
3. Lift the lid snaps so they are extended and place each lid snap into the corresponding hook on the housing back.
4. To close the housing, push down on the opposing lid snaps simultaneously until they snap into place. Be sure they are down far enough to engage the **lock** - **Page 9**. The o-ring seal should now appear as a solid black line from the back of the housing.

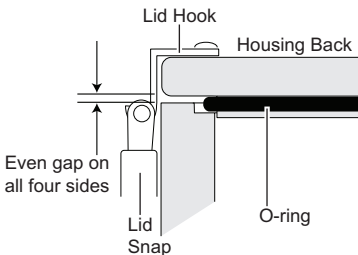

## STEP 6 - Attach Optional Mirrorless Lens Ports

**⚠ CAUTION:** This housing **does not** come with a lens port. An optional Mirrorless Lens Port must be properly attached to the housing **before** submersion in water; see [ikelite.com](http://ikelite.com) for compatible lens/port combinations. After purchasing an optional port for your lens, reference your port instruction manual for proper installation procedure. Once the Port is properly installed, you can test the housing for watertightness without a camera inside to ensure all housing seals are working properly.

DO NOT leave the Optional Lens Port off the Port Base for extended periods of time. This can result in debris being attracted to the Port Base O-ring, **Diagram C, page 11**, resulting in a bad seal.

## STEP 7 - Final Check

The clear housing permits instant visual inspection of the camera and sealing surfaces as well as complete monitoring of controls and camera LCD screens. This housing has been factory water pressure tested to 200 ft (60 m).

Once the housing is closed, recheck the o-ring seal. Double check the gap between the housing back and the housing. It should be even all the way around the housing.

Look through the clear plastic back at the o-ring. You should see a darkened area or solid black line where the o-ring is compressed against the housing back. If you do not see an even black compression seal all the way around the back, open the lid snaps, reseal the housing back and close the lid snaps. Visually check the seal again.

## USAGE

Turn the camera on and operate each of the housing controls to get a feel for using the camera in the housing.

## Entering the Water

As soon as you enter the water, take a moment and check to see that the housing is properly sealed. We recommend you first water test the housing with no camera inside to assure a safe and watertight environment.

Next, check to see if there are any bubbles on the face of the lens port. If there are, take your finger and remove them. If there are bubbles on the lens port they can produce soft focus spots in your photos or video.

## Removing the Camera from the Housing

1. Thoroughly dry housing.
2. Remove the housing back, **see Step 3, Opening the Housing, Page 9**.
3. Remove the Hotshoe from the camera mount.
4. Grab the thumbscrew with your thumb and index finger. Slowly and gently pull the camera backward to separate from housing, **Diagram D**. Continue pulling the camera backward and remove from housing. We recommend doing this procedure on a desktop or solid flat surface to avoid dropping the camera.

If you are finished using the housing, remove the Mounting Tray from the camera bottom and slide it back into the Housing Mounting Plate, then replace the Housing Back. For storage and travel, remove the back o-ring and place in a small plastic bag. Place the bag inside the housing and reattach the housing back.

**Note:** The Mounting Tray **MUST** be removed when changing a camera battery or SD card.

**Diagram D**

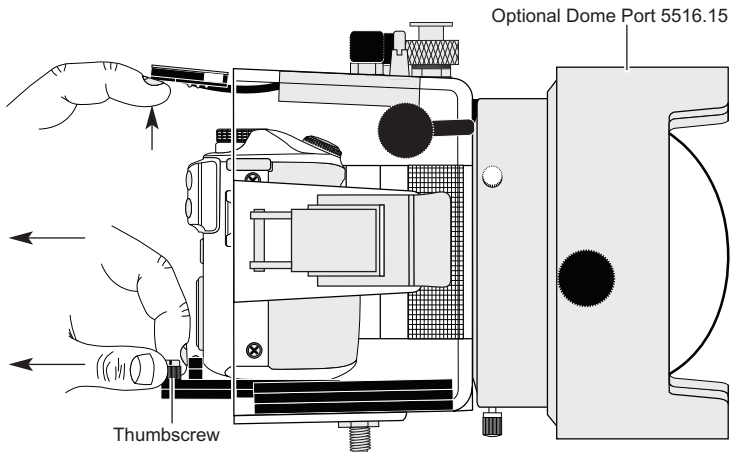

## STROBE COMPATIBILITY and CONNECTION

### Strobe Compatibility

- AF35.....no
- DS50.....yes, above serial number 70000
- DS51.....yes
- DS125.....yes, above serial number 5000
- DS160, DS161 .....yes
- DS200.....yes, above serial number 7163
- Non-Ikelite .....yes, manual flash exposure only

### Ikelite Housing Conversion Circuitry

This small compact housing has Ikelite designed and patented Conversion Circuitry built right in. The Conversion Circuitry provides real TTL flash exposure when used with Ikelite DS series strobes. The Circuitry is automatically activated once a DS series strobe is attached to the housing and turned on. Once attached, turn the strobe on first before turning on the camera. The circuitry cannot be powered up or used by non-Ikelite strobes.

**For MANUAL flash operation:** Depress the  button 4 consecutive times rapidly to switch from TTL to Manual flash mode. To return to TTL mode, turn the strobe off and on again, and then return the strobe to TTL operation.

### Attach Ikelite Sync Cord to the Housing and Strobe

*Reference Diagram E, Page 16*

The Ikelite Housing and Strobe Bulkheads are designed to accept sync cords with Ikelite 5 pin connector fittings.

1. Lightly lubricate the Sync Cord O-rings. Use **ONLY** Ikelite lubricant (supplied with housing). Other lubricants may cause the o-rings to swell and seal improperly.
2. Remove Bulkhead Caps from Housing Bulkhead and Strobe Bulkhead.

## Attach Ikelite Sync Cord to the Housing and Strobe - cont.

- Line up the Sync Cord Pins with the corresponding Bulkhead Receptacles. Gently insert Sync Cord ends into each Bulkhead. Either Cord End may be attached to a component. **DO NOT** force this installation. *If the Sync Cord does not seat properly inside the Bulkhead, then the Pins and Receptacles are improperly aligned (repeat Step 3).*
  - Tighten the Knurled Nuts snugly using your Index finger and thumb. **DO NOT** use pliers or other tools to tighten the Knurled Nuts.
- *Always remove the Sync Cord from your Housing and Strobe when not in use and replace the Bulkhead Caps.*

**Diagram E**

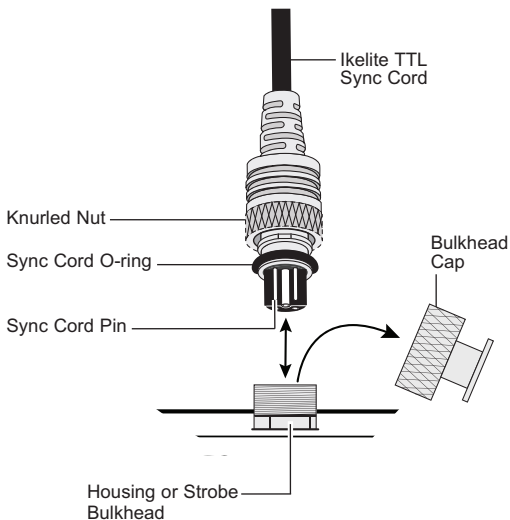



## Attach Ikelite Strobe Arm to the Housing Handle

To attach an Ikelite Arm to your Housing Handle, depress the spring-loaded Handle Push Button until it stops. Gently slide the pronged end of the Ikelite Arm into the hole in the top of the Handle as shown below, **Diagram F**.

When the Ikelite Arm is properly seated, the Handle Push Button will return to its starting position.

Diagram F

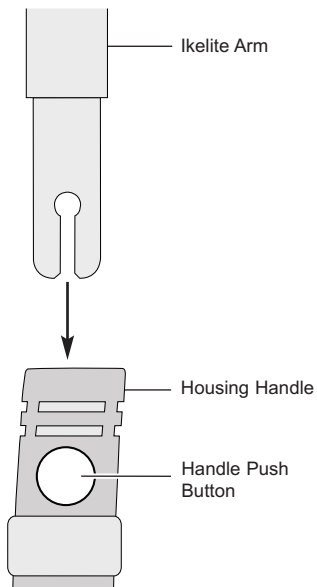

## SPARE PARTS - available through Ikelite or any Ikelite Dealer

- 0184.2 Silicone lubricant 2cc reclosable tube
- 9104.5 Waterproof bulkhead cap
- 0110 Main o-ring
- 0132.36 Port base o-ring

## RECOMMENDED ACCESSORIES

### Mirrorless Interchangeable Lens Ports

Visit [ikelite.com](http://ikelite.com) to select the correct Mirrorless Ports for your lenses.

### Tray + Dual Handles 9523.64

Attaching an optional Tray + Dual Handles will add stability and gripping point(s) for comfortable use of the housing. Add a second strobe to eliminate shadows and evenly light your subjects.



### Video Lighting

External video lights such as the 2101 Vega Light add color when shooting video. Primary video lights are specially color balanced to provide natural tones.

A full range of accessories are available to support your housing. Please visit [ikelite.com](http://ikelite.com) to see the most current information about recommended accessories for your housing.

## MAINTENANCE

### Lens Port

After use, rinse and gently dry the outside lens port with a non-abrasive cloth to avoid water spotting. Do not rinse inside the Port. To clean, use a mild soap solution or lens cleaner. It is NOT necessary to remove the Port for cleaning.

 **Do not use Rain-X, alcohol, window cleaner, or any other cleaning solution on the Lens Port.**

### Lubricant

Ikelite provides silicone lubricant with the housing. We recommend you use **only** Ikelite lubricant on Ikelite products. Other brands may cause o-rings to swell and not seal properly.

Use only enough lubricant to lightly cover the Port Base O-ring, or lubricate a sticky control. Wipe off any excess lubricant with a clean cloth. Lubricant is not a sealant; it is used to reduce friction. Excessive lubricant can collect sand, hair and dirt which may interfere with proper sealing.

 **CAUTION: Never use spray lubricants as the propellant ingredient can cause the plastic housing to crack or o-rings to swell. Use Ikelite lubricant only.**

## Housing Maintenance

Your Ikelite Digital Housing should be given the same care and attention as your other photographic and video equipment. In addition to normal maintenance, we recommend that the housing be returned to Ikelite periodically to be checked and pressure tested.

- **Do Not** leave the camera and housing in direct sunlight for prolonged periods. Heat may damage the camera.
- **Do Not** ship the camera in the housing.
- Before using the housing, always check the tightness of the **set screw** in each control knob. Check each **control gland** penetrating the housing to make sure they are tight. There is a slight chance that either could vibrate loose during travel.
- Keep the Port Base O-ring clean and lightly lubricated. To lubricate, place a small amount of Ikelite lubricant on your fingers and rub the lubricant over the exposed o-ring surface. If removing the o-ring to lubricate, do not use metal objects that may scratch the o-ring sealing surface. Only apply enough lubricant to make the o-ring feel slick. **Do not stretch the o-ring**. This light coating of lubricant will allow Mirrorless Ports to slide more easily over the Port Base.
- Keep the area where the housing o-ring fits and the sealing surface of the housing clean.
- Rinse the housing exterior thoroughly in freshwater after each saltwater use. Depress push buttons repeatedly in freshwater to eliminate trapped saltwater. Dry with a soft cloth. Dry lens port to eliminate water spotting. After several uses in saltwater, soak the housing exterior in a mild soap solution; rinse and dry before storing. When storing the housing, remove the back o-ring and place in a plastic bag. Place the plastic bag inside the housing for safe keeping.
- If removing a housing push button, **Do Not** re-use the E-clip. Contact Ikelite for replacement E-clips (part 0319.12).
- Leave lid snaps in the open position when not using the housing for extended periods.

## Control Maintenance

*Ikelite controls are designed to provide years of reliable service with minimal maintenance.*

- Push button controls normally require no maintenance other than rinsing in freshwater after saltwater use. Depress each push button in freshwater several times to eliminate trapped saltwater. If a push button control becomes difficult to push or if it sticks when depressed, soak the housing in luke warm freshwater. After a few minutes, operate the push button. If this does not correct the problem, return the housing to Ikelite for maintenance. If you are on a trip and unable to return the housing immediately, a push button may be lubricated by pressing and holding the push button all the way in. Then, use your finger or other small non-metal object to place a small amount of lube at the base of the shaft inside the housing. Press and release the push button several times until the lube is worked up into the o-ring.

After completing this procedure, close the housing and submerge it in water without the camera inside. Check the control for watertightness.

**Diagram G**

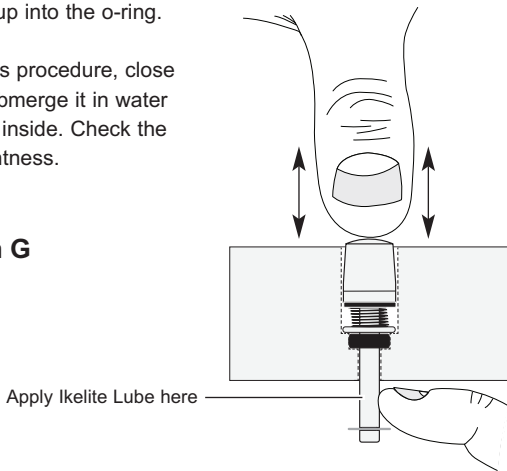

## Control Maintenance - continued

- In the unlikely event one of the control shafts sticks or becomes difficult to operate, you can remove the control from the housing and lubricate it, or return the housing to Ikelite for maintenance.

Your housing features both **round** and **hex** style control glands. To remove a control in a **round** style gland, **Diagram H, page 24**, loosen the set screw in the knob (allen wrench required); remove the knob. If there is salt or dirt build-up on the exposed control shaft, clean the shaft. Open the housing and gently slide the control shaft out of the control gland. Clean and lightly lubricate the shaft and o-rings, including the large end of the shaft.

If there is a shutter spring on the Control Shaft, make sure it is in its proper position. Rotate the Shaft back and forth slightly to aid installation back into the Control Gland.

Replace the knob with the Set Screw over the Control Flat. The Set Screw in the knob should be tightened down against the flat area on the Control Shaft so the knob does not turn on the shaft.

- Some of the controls have long shafts and feature a **hex** style control gland. These controls can be pulled out, exposing the shaft, **Diagram I, page 24**.

To lubricate the control, gently pull on the knob until the stainless steel shaft is exposed. Lightly lubricate the shaft, then move the shaft in and out several times. This will lubricate the x-ring in the Ikelite control gland. This should be done before using the housing after a prolonged storage period, or once a week when the housing is in constant use.

## Control Maintenance - continued

- Some of the controls have a short shaft and cannot be pulled out exposing the shaft for lubrication. In the unlikely event one of these controls sticks or becomes difficult to operate you can remove the control from the housing and lubricate it, or return the housing to Ikelite for maintenance. To remove the control, **Diagram J, page 24**, loosen the set screw in the knob (allen wrench required); remove the knob. If there is salt or dirt build-up on the exposed control shaft, clean the shaft. Open the housing and gently slide the control shaft out of the control gland. Clean and lightly lubricate the shaft, including the end of the shaft. Slide the shaft back into the control gland and gently slide the shaft back and forth a few times without fully removing the shaft from the gland. Replace the knob noting the flat area on the shaft. The set screw in the knob should tighten down against the flat area on the control, so the knob does not turn on the shaft.  
Close housing **without** a camera inside and water pressure test in a bathtub or swimming pool. Rotate\* the knobs to make sure the housing is watertight and the gland was installed properly. Check all controls while the housing is submerged.

 **\*Caution:** If your housing has a shutter spring, **DO NOT** rotate the shutter control more than 1/16th of a rotation, otherwise, you may accidentally bend the shutter spring or cause the spring to “pop off” the control shaft.

## Diagram H

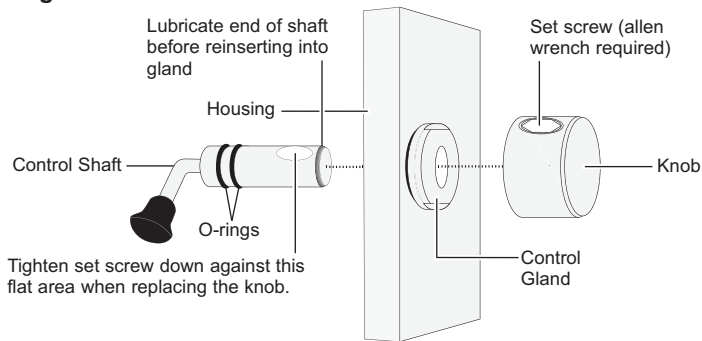

## Diagram I

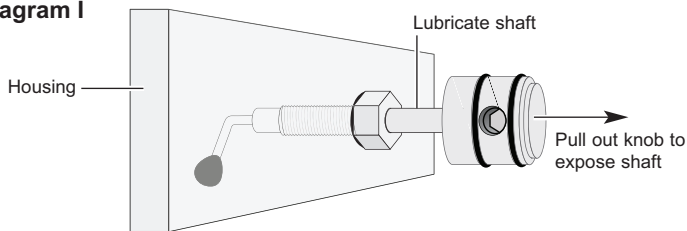

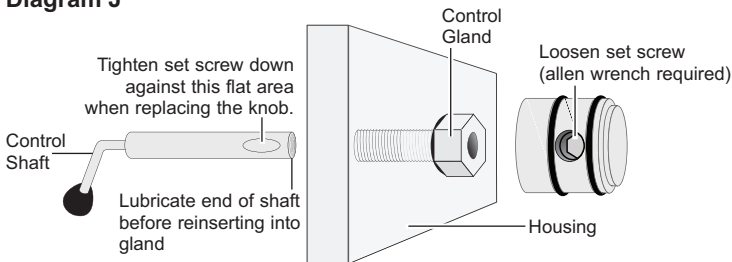

## Diagram J







## PHOTO TIPS

- The number one rule in underwater photography is to eliminate as much water between the camera and subject as possible. Get as close as you can to the subject, then use the zoom. If you are using flash for still photos, subjects beyond 6 feet (1.8 m) will not have much color regardless of strobe power.
- Photograph in clear water; do not stir up the sand or silty bottom. If backscatter becomes a problem in the environment you are photographing, an external flash will help eliminate much of the backscatter.
- Many digital cameras have a slight lag time between when you press the shutter release button and the camera actually takes the picture. Hold the housing steady a second or two after pressing the shutter release button.
- Do not shoot down on subjects as they will quite often blend into the background and be difficult to see in the photograph. Shoot subjects straight on or shoot up at a slight angle using the blue water as a contrasting background.
- When using daylight or flash, if your camera consistently over or underexposes the image, you may want to adjust your camera's exposure compensation  or flash exp. comp.   settings.
- If you error in exposure, it is better to have the image slightly underexposed rather than overexposed. An overexposed image is missing color information which cannot be adjusted in a photo processing program. A slightly underexposed image has color information that can be adjusted.
- It is important to respect all living creatures underwater, including people, marine life, and coral. While we encourage people to get close to their subjects when taking a photograph, they should not touch, lie on, or in any way disturb the things they find underwater.

## TROUBLESHOOTING

Problem	Solution
<b>Push buttons or controls are sticky or hard to operate</b>	<ul style="list-style-type: none"><li>- Remove the camera and rinse the closed housing in freshwater. Vigorously press each push button in and out several times to release any trapped saltwater or debris.</li><li>- Press a sticky push button all the way in and place a small amount of lube on the small end of the push button shaft at it's base. Release and operate the push button several times to distribute the lube, <b>Diagram G, Page 21</b>.</li><li>- If a larger gland style control is sticky, grab the control knob, pull it out, and then push back in. If still sticky, see the Control Maintenance section, <b>Page 22</b> and <b>Diagram H, Page 24</b>.</li><li>- Return housing to Ikelite for routine maintenance.</li></ul>
<b>Image is over/underexposed, or a corner of the image is dark</b>	<ul style="list-style-type: none"><li>- Check that the strobe is firing when taking a picture. Camera flash should be forced "on."</li><li>- When using an external strobe, make sure it is turned on, set properly, and its battery is charged.</li><li>- Reposition strobe(s).</li><li>- Check all corded connection points.</li><li>- Change camera shutter speed or aperture.</li><li>- Move closer to or further away from the subject.</li><li>- Adjust Flash Exposure Compensation  .</li></ul>

<b>Problem</b>	<b>Solution</b>
<b>Camera does not take a picture</b>	<ul style="list-style-type: none"> <li>- Install a fully charged battery.</li> <li>- There is not enough available light for the camera to properly focus. Add a focusing light or strobe with a built-in focusing/video light to your system.</li> <li>- Select a center focus point in your camera menu.</li> <li>- SD memory card is full.</li> </ul>
<b>Housing is hard to close</b>	<ul style="list-style-type: none"> <li>- Make sure the camera is mounted properly in the housing and controls are out of the way.</li> <li>- Main housing o-ring is not seated properly.</li> <li>- Hotshoe cord is in the way.</li> </ul>
<b>Fogging occurs on the Lens Port</b>	<ul style="list-style-type: none"> <li>- Humid air is trapped inside the housing. The camera produces heat and may condense any trapped moisture forming fog on the lens port. Close the housing in an air-conditioned room or vehicle, or in front of an air-conditioner.</li> <li>- The housing should not be in direct sunlight for an extended period of time.</li> <li>- Purchase desiccant packs also known as moisture munchers from a local camera store. Place one or two new packs in your housing before each day of diving.</li> <li>- If moisture or water droplets are present around the controls or sealing areas, return the housing to Ikelite for evaluation.</li> <li>- Clean the main housing o-ring and sealing surface of the housing.</li> </ul>

<b>Problem</b>	<b>Solution</b>
<b>Water enters the housing</b>	<ul style="list-style-type: none"> <li>- Remove, clean and properly lubricate the main o-ring.</li> <li>- Look for hair, dirt, or foreign debris crossing the o-ring seal.</li> <li>- Reassemble the housing without a camera installed and pressure test or take diving.</li> <li>- Return housing to Ikelite for evaluation.</li> </ul>
<b>Pictures are too blue or too green</b>	<ul style="list-style-type: none"> <li>- Use custom (manual) white balance when NOT using an external strobe. Reset for each working depth or when attaching a color correcting filter to the camera lens.</li> <li>- Move in closer to your subject when taking a picture.</li> <li>- Add an optional color correcting filter to the camera lens.</li> <li>- Add an external strobe.</li> </ul>

## **CUSTOMER SUPPORT**

Please read the troubleshooting section of this instruction manual before contacting Ikelite Customer Support.

**Ikelite Underwater Systems  
Service Department  
50 West 33rd St.  
Indianapolis, IN 46208 USA**

Email: [ikelite@ikelite.com](mailto:ikelite@ikelite.com)

Phone: 317-923-4523

## LIMITED WARRANTY

This Ikelite product is warranted against any manufacturing defects for a period of one (1) year from the original date of purchase. Defective products should be returned to Ikelite postage paid. Ikelite will, at its sole discretion, repair or replace such products, and will return to customer postage paid. All other claims of any nature are not covered. Except as mentioned above, no other warranty expressed or implied applies to this Ikelite product.

## RETURNING PRODUCTS for SERVICE

Ikelite is most interested in performing any service to ensure that all products perform as intended. Evidence of purchase date must be provided to obtain warranty service. No prior authorization is required. You may return directly to Ikelite or through an Ikelite dealer. Please include a brief description of the problem, any relevant email correspondence, and/or instructions on what services are required. Always include name, shipping address, email address, and phone number inside of the package. Send postage paid to:

**Ikelite Underwater Systems**  
**Attention: Service Department**  
**50 West 33 Street**  
**Indianapolis, IN 46208 USA**

- *No reimbursements for postage paid will be issued.*
- *You may also want to insure the package.*

## Returning Products for Service - outside the United States

For the separate international customs documentation form that you complete to accompany the shipment, please state or designate that the enclosed products were originally manufactured in the USA and are being returned to the manufacturer for repair service. Value of the equipment listed for customs purposes should be zero.

## PRODUCT REGISTRATION

Please go to **ikelite.com** to register your Ikelite housing within 15 days of purchase.



**Ikelite Underwater Systems**  
**50 West 33rd Street**  
**Indianapolis, IN 46208 USA**

**ikelite.com**