



Underwater TTL Housing for Panasonic GX7

Product Number 6970.07

Product Registration

Please register your product at ikelite.com within 15 days of purchase. Our product registration database is the best way for us to get a hold of you in the event of a product update or recall.

About this Product

Thank you for your purchase of Ikelite equipment. Please read this instruction manual completely before attempting to operate or dive with this product. Please visit ikelite.com to register your product to receive information on any updates, notices, or recalls pertaining to your equipment.

This product has been water pressure tested at the factory and is depth rated to 200 ft (60m). Thoroughly inspect and immerse the empty housing completely in water before installing a camera. If any fogging occurs or droplets of water enter the housing, do not install a camera. Clean the main housing o-ring and retest to make sure that it is watertight. If the problem persists, refer to the Troubleshooting section of this manual.

Please read your camera manual thoroughly to have a full understanding of each camera function.

If you are new to underwater photography, be sure to read the Photo Tips section of this manual.

Included in the Box

- Housing
- Instruction Manual
- Tray with Quick Release Handle
- Waterproof Bulkhead Cap (connected to external strobe connector)
- Silicone 1cc Lubricant Tube
- Cleaning Cloth
- 1/8-inch Allen Wrench

Specifications

- 200 ft (60m) depth rating
- All important camera functions are accessible
- Ikelite bulkhead connector with built-in TTL circuitry
- Slightly negative buoyancy in fresh water
- Actual buoyancy varies depending on choice of lens and port
- Weight 3.13 lb (1423 g) not including tray, handles or port
- Dimensions 6 x 7.7 x 5.2 in (152 x 196 x 132 mm) including projections

Contents

- 1 Product Registration**
- 2 About this Product**
- 3 Included in the Box**
- 3 Specifications**
- 6 Parts of the Housing - Front View**
- 7 Parts of the Housing - Back View**
- 8 HOUSING CAMERA AND SETUP**
- 8 STEP 1 - Remove/Attach Tray and Handle**
- 9 STEP 2 - Initial Camera Settings**
- 10 STEP 3 - Opening the Housing**
- 10 STEP 4 - Installing Camera in the Housing**
- 13 STEP 5 - Attach the Hotshoe**
- 13 STEP 6 - Closing the Housing**
- 14 STEP 7 - Attach Optional Mirrorless Lens Port**
- 14 STEP 8 - Final Check**
- 14 USAGE**
- 15 Entering the Water**

Contents - continued

- 15 Removing the Camera from the Housing**
- 16 STROBE USE AND COMPATIBILITY**
- 16 Strobe Compatibility**
- 16 Ikelite Housing Conversion Circuitry**
- 16 Camera Flash and Fiber Optic Use**
- 17 Attaching a Sync Cord to the Housing**
- 18 Attaching an Ikelite Strobe Arm to the Housing Handle**
- 19 SPARE PARTS**
- 19 RECOMMENDED ACCESSORIES**
- 20 MAINTENANCE**
- 24 PHOTO TIPS**
- 25 TROUBLESHOOTING**
- 27 Customer Support**
- 28 Limited Warranty**
- 28 Returning Products For Service**

Parts of the Housing - Front View

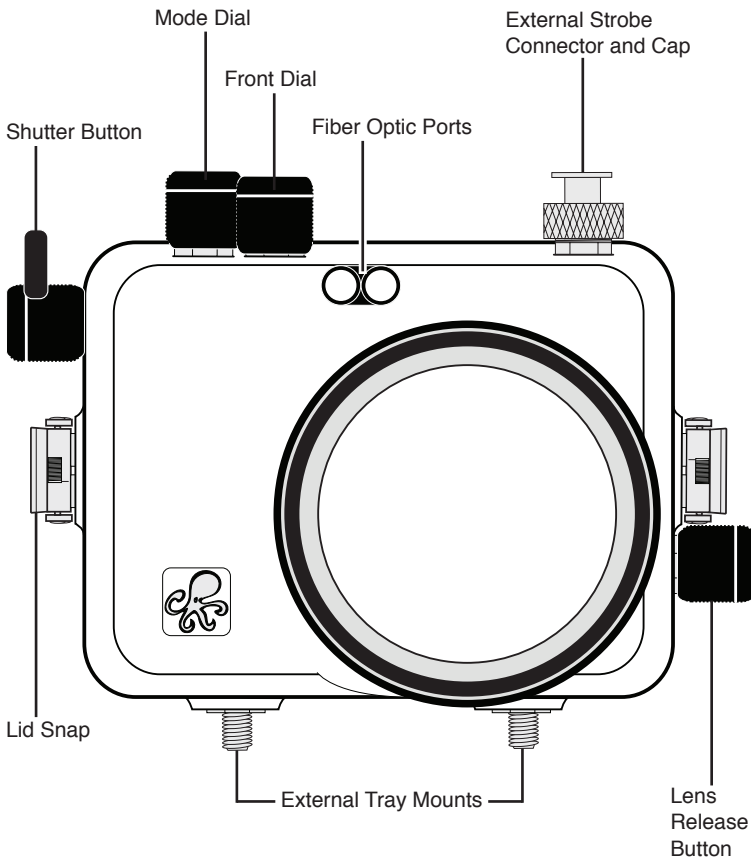

Parts of the Housing - Back View

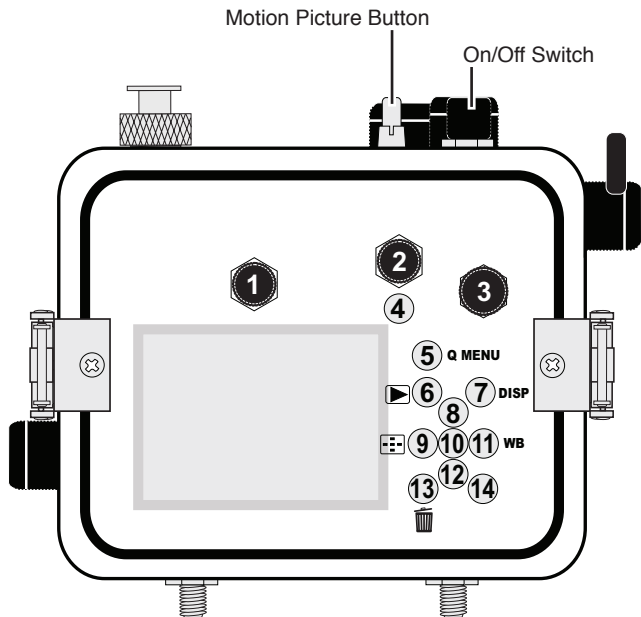

- | | |
|--------------------------------|-------------------------------------|
| 1. ⚡ Flash Open / LVF Button | 8. ISO/ Up Button |
| 2. Focus Mode Lever | 9. AF Mode / Left Button |
| 3. Rear Dial | 10. MENU/SET Button |
| 4. AF/AE Lock Button | 11. WB White Balance / Right Button |
| 5. Q. MENU Button | 12. Drive Mode / Down Button |
| 6. ▶ Playback Button | 13. 🗑 Delete / Cancel Button |
| 7. DISP. Display Button | 14. Wi-Fi Button |

HOUSING AND CAMERA SETUP

STEP 1 - Remove/Attach Tray and Handle



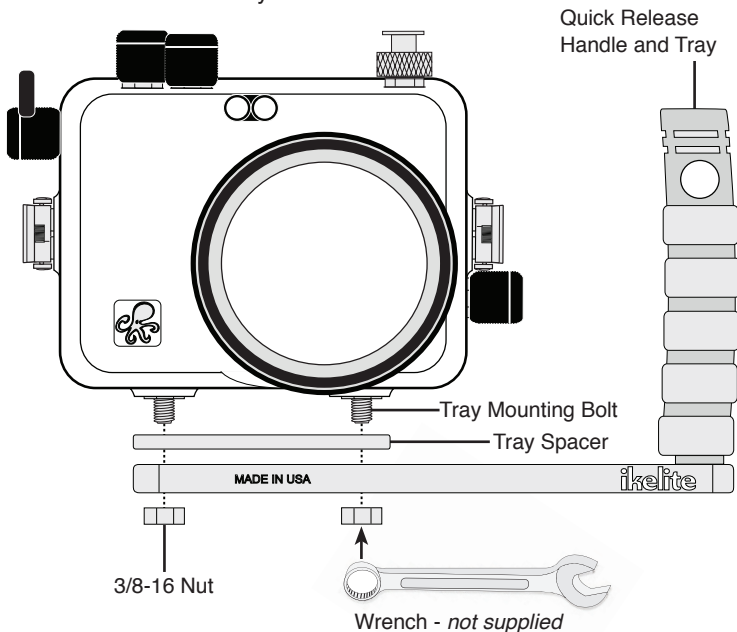

The Tray and Handle may be removed for transport and then re-attached for housing use. We recommend leaving the Tray and Handle attached whenever possible to avoid accidentally scratching table tops or other surfaces with the Tray Mounting Bolts.

To remove, loosen both 3/8-16 Nuts using a 9/16" open/box end or socket Wrench (not supplied). Do not lose Tray Spacer; it is needed for re-attachment of Tray and Handle.



STEP 2 - Initial Camera Settings (before placing camera in housing)

Read your camera owner's manual completely to familiarize yourself with all the camera functions. Setup your camera for underwater use with these initial camera settings and then make adjustments once underwater.

- Insert a fully charged camera battery and a SD card.
- Turn camera on and set Mode Dial to "A" Aperture Priority. Shutter speed will be locked at 1/60th second when the camera flash is activated or a DS-series strobe is attached. For faster shutter speeds, use "M" Manual mode. Other shooting modes are not recommended.
- **In  REC Menu:**
Set Aspect Ratio to "4:3" and Picture Size to "L 16m."
Set Quality to "Fine" or other desired setting.
Set Metering Mode to "Center-weighted" and i.Dynamic to "OFF."
In Flash, set Firing Mode to "TTL, Flash Mode to  and Flash Synchro to "1st."
Set Red-Eye Removal and Face Recog. to "OFF."
- **IN Q. MENU:**
Set AF Mode to "AFS" AF Single and "1-Area."
Set ISO to "200."
Set White Balance to "Auto." For best results set to manual White Balance "White Set 1  and reset for each working depth.
- **In  C MENU:**
Set Eye Sensor and AF Assist Lamp to "OFF."
- **In  MENU:**
Format the SD Card.
Set the Date and Time.
In Economy, set Sleep Mode and Auto Monitor Off to "5 MIN".

* *Settings not mentioned should be set to the user's preference.*

STEP 3 - Opening the Housing

Lid snaps have a **lock**.

1. Push Lid Snap Locks forward and lift as shown. Open opposing Lid Snaps simultaneously. Keep pressure on the lid snaps so they do not fly open quickly. Some Lid Snaps have a lot of spring tension once they go over center, so keep a firm grip on each Lid Snap. Lid Snaps may also be opened one at a time.
2. Remove the Housing Back.

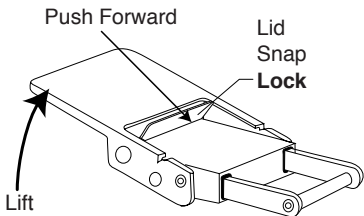

STEP 4 - Installing Camera in the Housing

1. Make sure the camera battery is fully charged and a SD card is inserted into the camera.
2. Rotate Housing Lens Release Button control up and forward against front of housing.
3. The Mounting Plate is secured to the inside bottom of the housing. The camera Mounting Tray slides into the Mounting Plate. Use the index and middle fingers of your hand to pull the Thumb Screw away from the Mounting Plate, **Diagram A, page 11**. Use your thumb to apply opposite pressure against the bottom of the housing to assist in removal of the Tray.

STEP 4 - Installing Camera in the Housing - continued

Diagram A

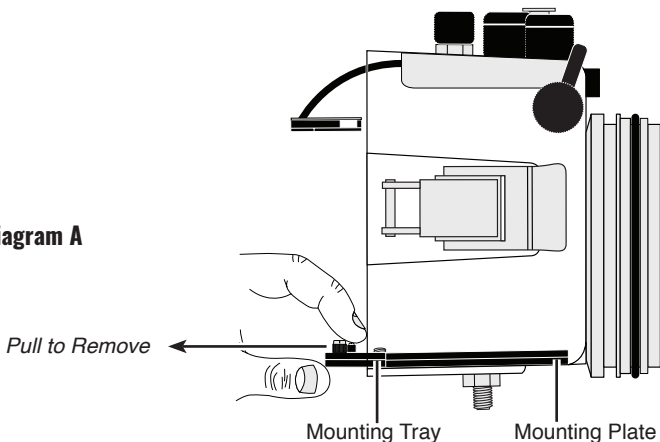

- Using a coin or flathead screwdriver (preferred), secure the camera Mounting Tray to the camera tripod mount, **Diagram B**. Tighten camera firmly to avoid movement on tray. The Mounting Tray only attaches one way with the Thumb Screw to the back of the camera.

- Gently slide the camera with Mounting Tray back into the Mounting Plate, **Diagram C, page 12**.

Using your thumbs, push against the Mounting Tray until it stops sliding forward into the Mounting Plate. Give the Tray an extra push to make sure it is properly seated all the way forward in the Mounting Plate, **Diagram D, page 12**.

Diagram B

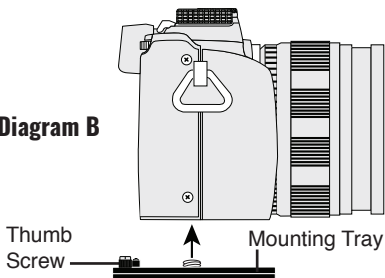

STEP 4 - Installing Camera in the Housing - continued

Diagram C

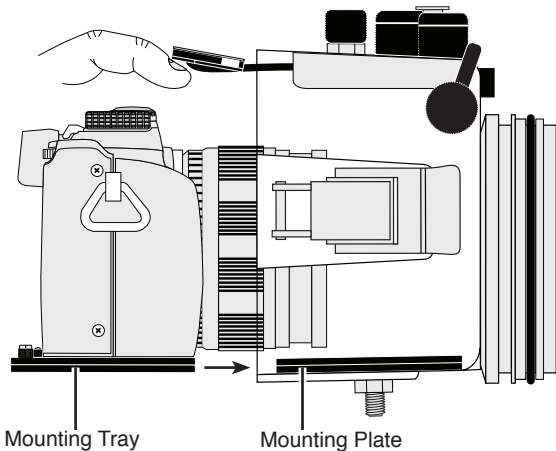
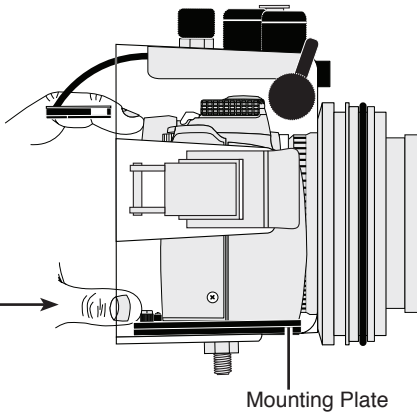

Diagram D

Push Camera and
Mounting Tray all
the way forward into
the Mounting Plate



STEP 5 - Attach the Hotshoe

Slide Hotshoe into the top camera mount until it stops. Hotshoe must be all the way forward in the camera mount to assure a good electrical connection with a strobe.

Make sure hotshoe cord does not interfere with controls or the housing back when closing the housing.

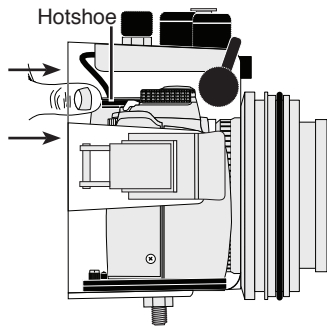

STEP 6 - Closing the Housing

1. Place housing face down in your lap or on a flat surface. Check to see that there is an o-ring on the housing back, and that it is clean and in its proper location.
2. Guide the back onto the housing front. Make sure the hotshoe wire is out of the way. Once the back is properly installed, the o-ring should touch the housing all the way around. There should be an even gap on each side of the housing between the housing and the back.
3. Lift the lid snaps so they are extended and place each lid snap into the corresponding hook on the housing back.
4. To close the housing, push down on the opposing lid snaps simultaneously until they snap into place. Be sure they are down far enough to engage the **lock - Page 10**. The o-ring seal should now appear as a solid black line from the back of the housing.

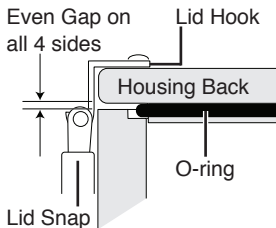

STEP 7 - Attach Optional Mirrorless Lens Port

⚠ CAUTION: This housing does NOT come with a lens port. An optional Mirrorless Lens Port must be properly attached to the housing before submersion in water; see ikelite.com for compatible lens/port combinations. After purchasing an optional port for your lens, reference your port instruction manual for proper installation procedure.

Once the Port is properly installed you can test the housing for watertightness without a camera inside to ensure all housing seals are working properly.

STEP 8 - Final Check

The clear housing permits instant visual inspection of the camera and sealing surfaces as well as complete monitoring of controls and camera LCD screens. This housing has been factory water pressure tested to 200 ft (60m).

Once the housing is closed, recheck the o-ring seal. Double check the gap between the housing back and the housing. It should be even all the way around the housing.

Look through the clear plastic back at the o-ring. You should see a darkened area or solid black line where the o-ring is compressed against the housing back. If you do not see an even black compression seal all the way around the back, open the lid snaps, reseal the housing back and close the lid snaps. Visually check the seal again.

USAGE

Turn the camera on and operate each of the housing controls to get a feel for using the camera in the housing.

Entering the Water

As soon as you enter the water, take a moment and check to see that the housing is properly sealed. We recommend you first water test the housing with no camera inside to assure a safe and watertight environment.

Next, check to see if there are any bubbles on the face of the lens port. If there are, take your finger and remove them. If there are bubbles on the lens port they can produce soft focus spots in your photos or video.

Removing the Camera from the Housing

1. Thoroughly dry housing.
2. Remove the housing back, see Opening the Housing, **Step 3, Page 10**.
3. Remove the Hotshoe from the camera mount.
4. Use the index and middle finger of a hand to pull the Thumb Screw away from the Mounting Plate, **Diagram A, page 11**.

If you are finished using the housing, remove the Mounting Tray from the camera bottom and slide it back into the Housing Mounting Plate, then replace the Housing Back. For storage and travel, remove the back o-ring and place in a small plastic bag. Place the bag inside the housing and re-attach the housing back.

Note: The Mounting Tray needs to be removed when changing a camera battery or memory card.

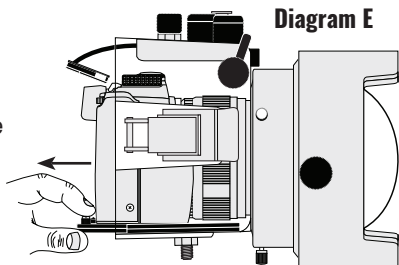

Optional Dome Port 5516.15

STROBE USE AND COMPATIBILITY

Strobe Compatibility

AF35	no
DS50	yes, above serial number 70,000
DS51	yes
DS125.....	yes, above serial number 5000
DS160, DS161....	yes
DS200.....	yes
Non-Ikelite	yes, manual flash exposure only

Ikelite Housing Conversion Circuitry

This small compact housing has Ikelite designed and patented Conversion Circuitry built right in. The Conversion Circuitry provides real TTL flash exposure when used with Ikelite DS series strobes. The Circuitry is automatically activated once a DS series strobe is attached to the housing and turned on. Once attached, turn the strobe on first before turning on the camera. The circuitry cannot be powered up or used by non-Ikelite strobes.

Camera Flash and Fiber Optic Use

The camera flash can be extended and used to trigger external strobes connected to the Fiber Optic Ports on the housing front - see diagram, **page 6**.

Note: DO NOT attempt to take underwater photographs using ONLY the camera flash. This will result in images containing dark spots since the flash is partially blocked by the Lens and Fiber Optic Ports.

Attaching a Sync Cord to the Housing

The Housing Bulkhead is designed to accept sync cords with Ikelite 5 pin/receptacle connector fittings.

1. Lightly lubricate the Sync Cord O-ring. Use **ONLY** Ikelite lubricant (supplied with housing).
 2. Remove Bulkhead Cap from Housing Bulkhead.
 3. Line up the Sync Cord Pins with the corresponding Bulkhead Receptacles. Gently insert Sync Cord into Bulkhead. **DO NOT** force this installation. If the Sync Cord does not seat properly inside the Bulkhead, then the Pins and Receptacles are improperly aligned (repeat Step 3).
 4. Tighten the Knurled Nut snugly using your Index finger and thumb. **DO NOT** use pliers or other tools to tighten the Knurled Nut.
- *Always remove the Sync Cord from your Housing when not in use and replace the Bulkhead Cap.*

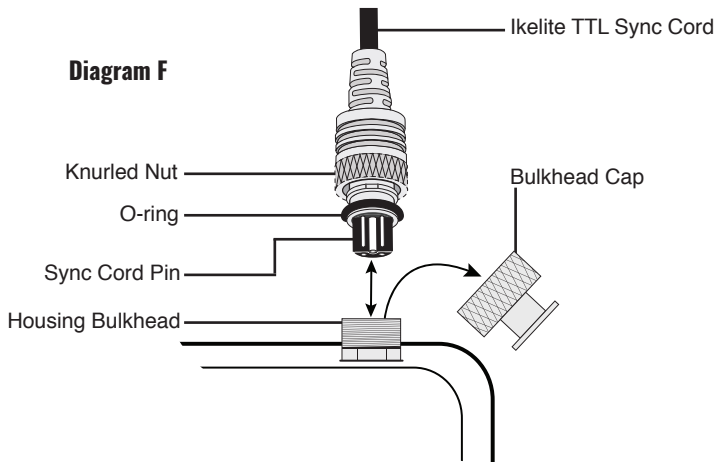

Attaching an Ikelite Strobe Arm to the Housing Handle

To attach an Ikelite Arm to your Housing Handle, depress the spring-loaded Handle Push Button until it stops. Gently slide the pronged end of the Ikelite Arm into the hole in the top of the Handle as shown, **Diagram G**.

When the Ikelite Arm is properly seated, the Handle Push Button will return to its starting position.

Diagram G

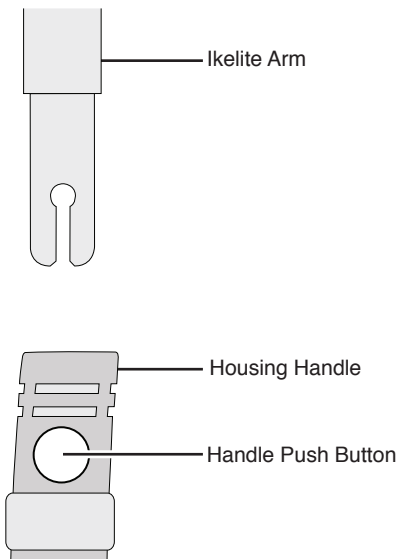

SPARE PARTS (available through Ikelite or any Ikelite Dealer)

0110 Main o-ring

0132.36..... Port Base O-ring

0184.2..... Silicone Lubricant 2cc Reclosable Tube

RECOMMENDED ACCESSORIES

Optional Mirrorless Interchangeable Lens Ports

Visit ikelite.com to select the correct Mirrorless Lens Ports for your lenses.

Tray + Dual Handles 9523.64

Add stability and additional gripping points for comfortable use of the housing. Attach a second video light to eliminate shadows and evenly light your subjects.

DS161 Strobe, Sync Cord + Ball Arm Mark II Kit 4061.31

The DS161 Strobe Kit combines power with wide angle coverage and provides everything you need to add a strobe to your Ikelite system. Instead of a simple focus light, the DS161 also includes a super even, 500 lumen video light.

Video Lighting

External video lights such as the 2101 Vega Light add color when shooting video. Primary video lights are specially color balanced to provide natural tones.

A full range of accessories are available to support your housing. Please visit ikelite.com to see the most current information about recommended accessories for your housing.

MAINTENANCE

Lens Port

After use, rinse and gently dry the outside lens port with a non-abrasive cloth to avoid water spotting. Do not rinse inside the Port. To clean, use a mild soap solution or lens cleaner. It is NOT necessary to remove the Port for cleaning.

⚠ CAUTION: DO NOT use Rain-X, alcohol, window cleaner, or any other cleaning solution on the Lens Port.

Lubricant

Ikelite provides silicone lubricant with the housing. We recommend you use only Ikelite lubricant on Ikelite products. Other brands may cause o-rings to swell and not seal properly.

Use only enough lubricant to lightly cover the Port Base O-ring, or lubricate a sticky control. Wipe off any excess lubricant with a clean cloth. Lubricant is not a sealant; it is used to reduce friction. Excessive lubricant can collect sand, hair and dirt which may interfere with proper sealing.

⚠ CAUTION: Never use spray lubricants as the propellant ingredient can cause the plastic housing to crack or o-rings to swell. Use Ikelite lubricant only.

Housing Maintenance

Your Ikelite Digital Housing should be given the same care and attention as your other photographic and video equipment. In addition to normal maintenance, we recommend that the housing be returned to Ikelite periodically to be checked and pressure tested.

Housing Maintenance - continued

- Do not leave the camera and housing in direct sunlight for prolonged periods. Heat may damage the camera.
- Do Not ship the camera in the housing.
- Before using the housing, always check the tightness of the set screw in each control knob. Check each control gland penetrating the housing to make sure they are tight. There is a slight chance that either could vibrate loose during travel.
- Keep the Port Base O-ring clean and lightly lubricated. To lubricate, place a small amount of Ikelite lubricant on your fingers and rub the lubricant over the exposed o-ring surface. If removing the o-ring to lubricate, do not use metal objects that may scratch the o-ring sealing surface. Only apply enough lubricant to make the o-ring feel slick. Do not stretch the o-ring. This light coating of lubricant will allow Ports to slide more easily over the Port Base.
- Keep the area where the housing o-ring fits and the sealing surface of the housing clean.
- Rinse the housing exterior thoroughly in freshwater after each saltwater use. Depress push buttons repeatedly in freshwater to eliminate trapped saltwater. Dry with a soft cloth. Dry lens port to eliminate water spotting. After several uses in saltwater, soak the housing exterior in a mild soap solution; rinse and dry before storing. When storing the housing, remove the back o-ring and place in a plastic bag. Place the plastic bag inside the housing for safe keeping.
- If removing a housing push button, Do Not re-use the E-clip. Contact Ikelite for replacement E-clips (part 0319.12).
- Leave lid snaps in the open position when not using the housing for extended periods.

Control Maintenance

Ikelite controls are designed to provide years of reliable service with minimal maintenance.

Push button controls normally require no maintenance other than rinsing in freshwater after saltwater use. Depress each push button in freshwater several times to eliminate trapped saltwater. If a push button control becomes difficult to push or if it sticks when depressed, soak the housing in warm freshwater. After a few minutes, operate the push button. If this does not correct the problem, return the housing to Ikelite for maintenance. If you are on a trip and unable to return the housing immediately,

a push button may be lubricated by pressing and holding the push button all the way in. Then, use your finger or other small non-metal object to place a small amount of lube at the base of the shaft inside the housing. Press and release the push button several times until the lube is worked up into the o-ring.

After completing this procedure, close the housing and submerge it in water without the camera inside. Check the control for watertightness.

Diagram H

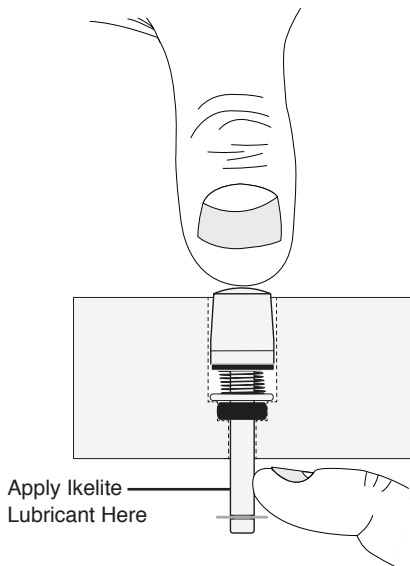

Control Maintenance - continued

In the unlikely event one of the larger gland style control shafts sticks or becomes difficult to operate, you can remove the control from the housing and lubricate it, or return the housing to Ikelite for maintenance. To remove the control, Diagram I, loosen the set screw in the knob (hex head wrench required); remove the knob. If there is salt or dirt build-up on the exposed control shaft, clean the shaft. Open the housing and gently slide the control shaft out of the control gland. Clean and lightly lubricate the shaft, including the end of the shaft.

Slide the shaft back into the control gland and gently slide it back and forth a few times without fully removing the shaft from the gland. Replace the knob, noting the flat area on the shaft. The set screw in the knob should tighten down against the flat area on the control shaft so the knob does not turn on the shaft.

After completing this procedure, close the housing and submerge it in water without the camera inside. Check the control for watertightness.

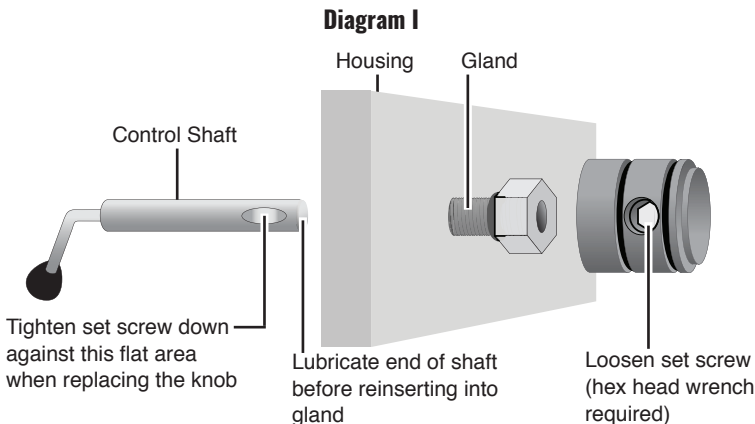





PHOTO TIPS

- The number one rule in underwater photography is to eliminate as much water between the camera and subject as possible. Get as close as you can to the subject, then use the zoom. If you are using flash for still photos, subjects beyond 6 feet (1.8m) will not have much color regardless of strobe power.
- Photograph in clear water; do not stir up the sand or silty bottom. If backscatter becomes a problem in the environment you are photographing, an external flash will help eliminate much of the backscatter.
- Many digital cameras have a slight lag time between when you press the shutter release button and the camera actually takes the picture. Hold the housing steady a second or two after pressing the shutter release button.
- Do not shoot down on subjects as they will quite often blend into the background and be difficult to see in the photograph. Shoot subjects straight on or shoot up at a slight angle using the blue water as a contrasting background.
- When using daylight or flash, if your camera consistently over or underexposes the image, you may want to adjust your camera's exposure compensation  or flash exp. comp.  settings.
- If you error in exposure, it is better to have the image slightly underexposed rather than overexposed. An overexposed image is missing color information which cannot be adjusted in a photo processing program. A slightly underexposed image has color information that can be adjusted.
- It is important to respect all living creatures underwater, including people, marine life, and coral. While we encourage people to get close to their subjects when taking a photograph, they should not touch, lie on, or in any way disturb the things they find underwater.

TROUBLESHOOTING

<p>Push buttons or controls are sticky or hard to operate</p>	<ul style="list-style-type: none">• Remove the camera and rinse the closed housing in freshwater. Vigorously press each push button in and out several times to release any trapped saltwater or debris.• Press a sticky push button all the way in and place a small amount of lube on the small end of the push button shaft at it's base. Release and operate the push button several times to distribute the lube, Diagram H, Page 22.• If a larger gland style control is sticky, grab the control knob, pull it out, and then push back in. If still sticky, see the Control Maintenance section, Diagram I, Page 23.• Return housing to Ikelite for routine maintenance.
<p>Image is over/under-exposed, or a corner of the image is dark</p>	<ul style="list-style-type: none">• Check to see the strobe or camera flash is firing when taking a picture• Adjust your camera settings.• Move closer to or farther away from the subject. Optimal distance is approximately 3 feet (1 m) or less.• Position your strobe(s) closer to or farther away from your subject.• Reposition your strobe to better light the subject.• Adjust Flash Exposure Compensation  .

Troubleshooting - continued

<p>Camera does not take a picture</p>	<ul style="list-style-type: none">• Install a fully charged battery.• There is not enough available light for the camera to properly focus. Add a focusing light or strobe with a built-in focusing or video light to your system.• Select a center focus point in your camera menu.
<p>Housing is hard to close</p>	<ul style="list-style-type: none">• Make sure the camera is mounted properly in the housing and controls are out of the way.• Main housing o-ring is not seated properly.• Hotshoe cord is in the way.
<p>Fogging occurs on the Lens Port</p>	<ul style="list-style-type: none">• Humid air is trapped inside the housing. The camera produces heat and may condense any trapped moisture forming fog on the lens port. Close the housing in an air-conditioned room or vehicle, or in front of an air-conditioner.• The housing should not be in direct sunlight for an extended period of time.• Purchase desiccant packs from a local camera store. Place one or two new packs in your housing before each day of diving.• If moisture or water droplets are present around the controls or sealing areas, return the housing to Ikelite for evaluation.• Clean the main housing o-ring and sealing surface of the housing.

Troubleshooting - continued

<p>Pictures are too blue or too green</p>	<ul style="list-style-type: none">• Add an optional color correcting filter to the camera lens when not using a strobe.• Add an external strobe.• Move in closer to your subject when taking a picture.• Use custom (manual) white balance. Reset for each working depth or when attaching a color correcting filter to the camera lens.
<p>Water enters the housing</p>	<ul style="list-style-type: none">• Remove, clean, and properly lubricate the main o-ring.• Look for hair, dirt, or foreign debris crossing the o-ring seal.• Reassemble the housing without a camera installed and pressure test or take diving.• Return housing to Ikelite for evaluation.

Limited Warranty

This product is warranted against manufacturing defects for a period of one year from the date of purchase. Defective products should be returned prepaid to Ikelite. Ikelite will, at its discretion, (a) repair utilizing new, remanufactured, and/or recycled parts; (b) exchange for a new product or; (c) exchange for a refurbished product; and return to customer prepaid. All other claims, of any nature, are not covered. Except as mentioned above, no other warranty, express or implied, applies to this product.

Service and Repairs

Ikelite is most interested in performing any service to ensure that all products perform as intended. Evidence of purchase date must be provided to obtain warranty service.

No prior authorization is required. You may return directly to us or through your dealer. Please include a brief description of the problem, any relevant email correspondence, and/or instructions on what you want us to do. Always include name, shipping address, email address, and phone number inside of the package. Send postage paid to:

Ikelite Service Dept.
50 West 33 Street
Indianapolis, IN 46208 USA

No reimbursements for postage paid will be issued. You may also want to insure the package.

For the separate international customs documentation form that you complete to accompany the shipment, please state or designate that the enclosed products were originally manufactured in the USA and are being returned to the manufacturer for repair service. Value of the equipment listed for customs purposes should be zero.

Contact Us

Ikelite Underwater Systems
50 W 33rd St
Indianapolis, IN 46208 USA
(317) 923-4523
ikelite.com

© 2014 Ikelite Underwater Systems