

# Ikelite SLR-DC Housing

instruction manual

#6801.50 for Nikon D5000



Congratulations on your purchase of an Ikelite Digital Camera Housing. Ikelite has over 45 years of experience in the underwater photographic and lighting market. Our products are designed and built in the USA by Ikelite for both the professional and amateur photographer.

The clear housing permits instant visual inspection of the camera and all sealing surfaces as well as complete monitoring of controls and camera LCD screens.

Ikelite Digital Housings are slightly negative in salt water for stability. This housing has been water pressure tested at the factory. Housing is pressure tested to 200' (60m).

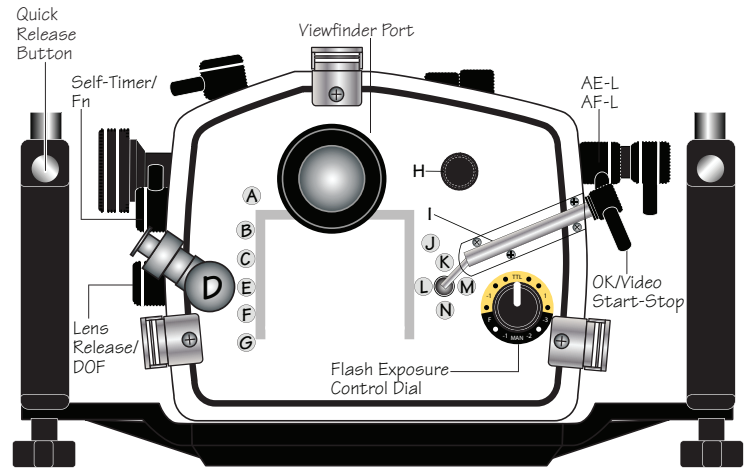

- |  |                         |
|--|-------------------------|
| [A] Delete                             | [H] Command Dial        |
| [B] Playback                           | [I] OK/Video Start-Stop |
| [C] Menu                               | [J] Live-View           |
| [D] Ext. Strobe Conn. & Waterproof Cap | [K] Cursor up           |
| [E] Playback Zoom-out                  | [L] Cancel & Return     |
| [F] Playback Zoom-in                   | [M] Select item         |
| [G] Info Button                        | [N] Cursor Down         |

## BACK VIEW

2

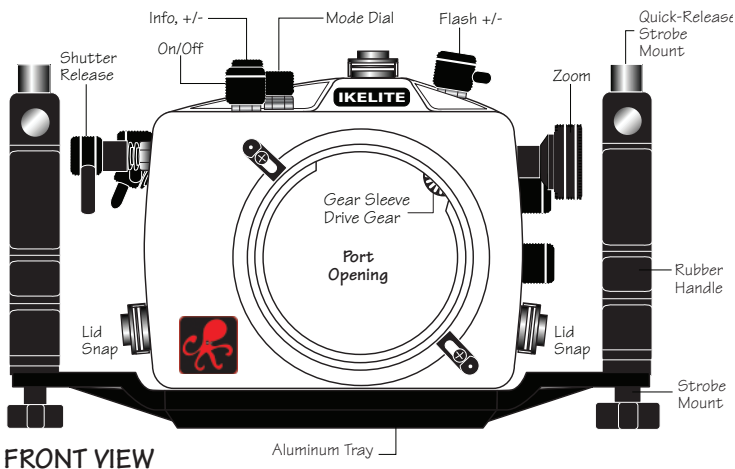

## FRONT VIEW

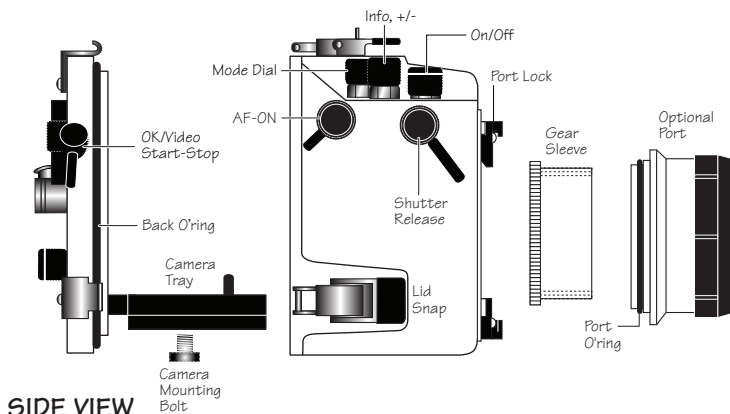

## SIDE VIEW

3

## Initial Camera Setup

- Insert a fully charged battery.
- Insert memory card (1GB or greater capacity recommended).
- Set the mode dial to "M" manual.
- Set shutter speed to 1/60th second or 1/125th second for fast moving subjects.
- Set aperture to F8 for general photography or F22 for macro photography (close-ups).
- Set Image Quality to Fine or RAW.
- Set ISO to Lo1 (100) or 200.
- Set Meter to "center-weighted".
- Set White Balance to "Auto" or "Flash".
- Make sure Red-Eye Reduction is NOT enabled.

## Opening the Housing

Lid Snaps have a **Lock**. To open, push Lid Snap Lock forward and lift as shown. Keep pressure on the Lid Snap so it does not fly open quickly. *Some lid snaps have a lot of spring tension once they go over center, so have a firm grip on the lid snap. Lid Snaps may be opened one at a time.*

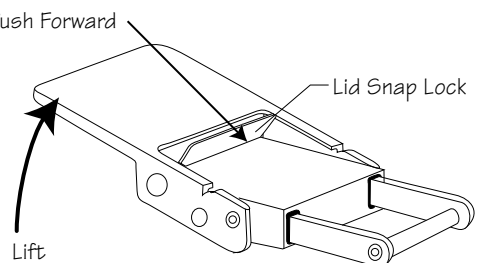

4

## Installing the Camera

Remove the back from the housing. The mounting tray for the camera is secured to the housing back. Position the camera and lens on the tray, and then secure it with the mounting bolt which threads into the camera's tripod socket. Use a flathead screwdriver (recommended) or coin to tighten the mounting bolt so the camera bottom is flush against the tray.

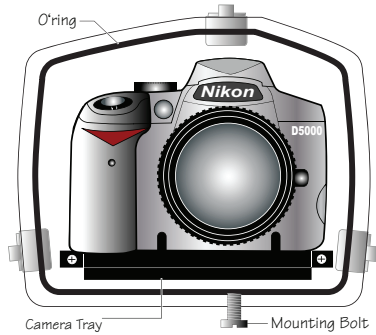

**NOTE:** Conversion Circuitry Strobe ID Switch is located on bottom of camera tray.

## Setting the Conversion Circuitry Strobe ID Switch.

On the bottom of the camera tray is a switch for setting the DS Substrobe ID. Set the switch to the Model of DS Substrobe being used.

- When using dual strobes of different models such as a DS51 and a DS125, set the ID switch to DS51 or the smaller strobe.

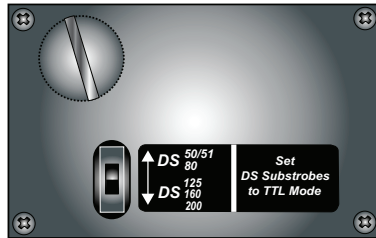

5

## Closing the Housing

1. Place housing face down in your lap.
2. Check to see that there is an o-ring on the housing back that is clean and in its proper location.
3. Guide the back onto the housing. The o-ring should touch the housing all the way around. There should be an even gap all the way around between the housing and the housing back.
4. Lift the lid snaps so they are extended and place the lid snap into the corresponding hook on the housing back.
5. To close the housing, push down on the lid snaps until they snap into place. Lid snaps on opposite sides of the housing should be closed at the same time. Be sure they are down far enough to engage the lid-snap lock.

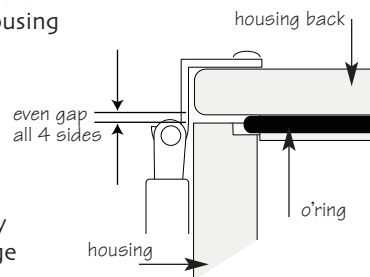
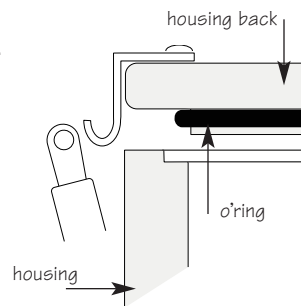

**Double check** - Once the housing is closed, check the o-ring seal. Check the gap between the housing back and the housing, it should be even all the way around.

Look through the clear plastic back at the o-ring. You should see a darkened area where the o-ring is compressed against the housing back. If you do not see an even black compression seal all the way around the back, open the lid snaps, reseal the housing back, and then close the lid snaps. Visually check the seal again.

7

## Flash Connection for External Strobes

When using an external strobe, connect the housing hotshoe connector. Slide the connector into the hotshoe mount on the camera from the back of the camera as shown. Slide the connector forward until it stops. This can be done before or after the camera is secured with the mounting bolt.

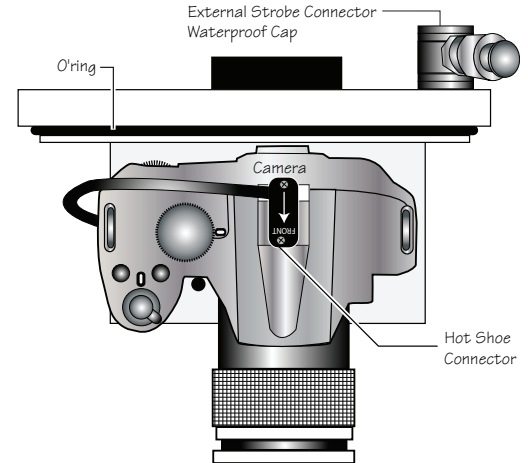

### Caution:

Do not remove the External Strobe Connector's waterproof cap unless an external sync cord is going to be plugged in. Do not remove waterproof cap or sync cord underwater.

## Installing Camera in Housing

Before installing the camera, pull out on the controls in the front section of the housing. This will allow the camera to slide in more easily. Once the camera is installed and the lid snaps have been closed, return the controls to their operating position.

6

## Preparing to Install Zoom Clamp & Gear Sleeve

Determine the type of lens being used on the camera.

Type 1 Lenses have a lens opening that is NOT larger in diameter than the zoom ring. (Fig. 1).

Type 2 Lenses have a lens opening that IS larger in diameter than the zoom ring. (Fig. 2).

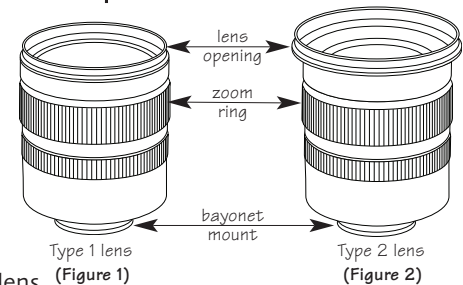

## Zoom Clamps & Gear Sleeves Included with Housing

There are 2 different Zoom Clamps and Gear Sleeves provided with the housing. Start with the suggested Zoom Clamp and Gear Sleeve depending on the Type of lens being used. See (Fig. A or B)

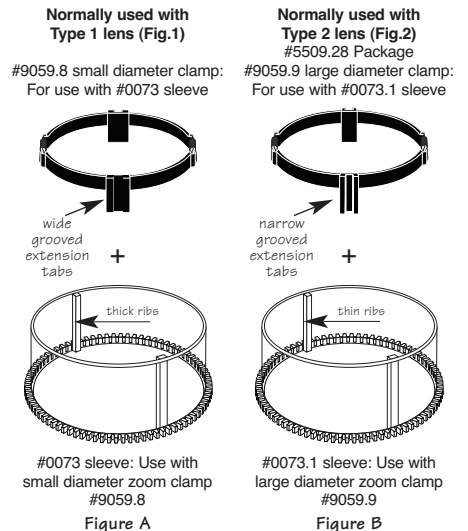

8

## Installing the Zoom Clamp & Gear Sleeve On the Type 1 Lenses

The Zoom Clamp has springs so it can be expanded to fit over the Zoom Ring of the lens as shown in (Fig. C). Install the Zoom Clamp with the extension tabs toward the rear element of the lens. After installing the Zoom Clamp and Gear Sleeve (Fig. D & E), install the Lens Port and rotate the Zoom Ring on the lens. If the Zoom Ring and Gear Sleeve do not mesh properly, install the rubber strips (supplied) to the inside diameter of the Zoom Clamp as shown (Fig. F). Two thicknesses of rubber strips are provided. Start by installing the thinnest rubber strips. If the Zoom Clamp still is not tight enough and meshes improperly with the Gear Sleeve, use the thicker rubber strips. Reinstall the Zoom Clamp, Sleeve, and Port. Mesh Gear Sleeve teeth with Black Housing Drive Gear (Fig. G-Page #12)

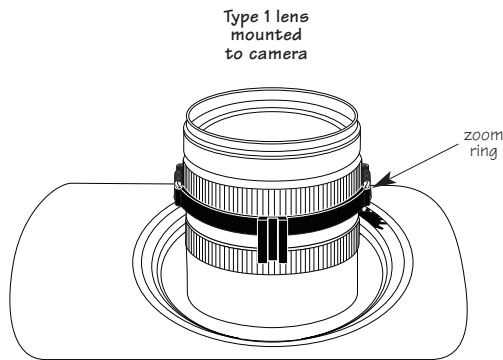

Figure C

9

## Type 1 Lenses (continued)

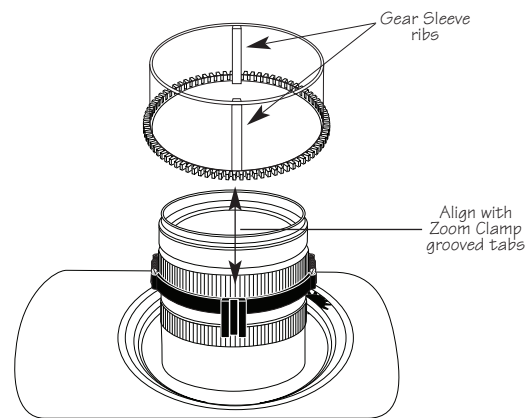

Figure D

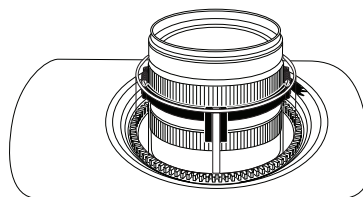

Figure E

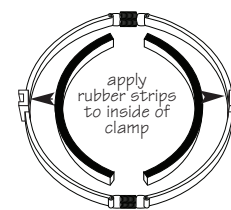
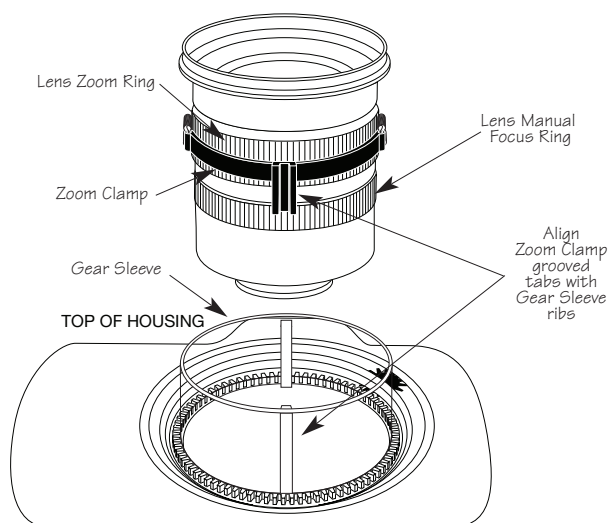

Figure F

10

## Installing the Zoom Clamp & Gear Sleeve On Type 2 Lenses

Due to the larger diameter lens opening on Type 2 lenses, the Zoom Clamp and Gear Sleeve need to be installed from the rear (bayonet end) of the lens. Use the housing Lens Release Control and remove the camera lens from the camera body, after the camera and lens have been installed in the housing.



Type 2 lens

### Manual Focusing Note:

Ikelite DSLR housings are designed for auto-focus DSLR cameras and lenses. Manual focusing is not recommended. If you desire to manually focus a lens, the zoom clamp must be moved onto the lens Manual Focus Ring and you must use the housing zoom control knob to manually focus. This will result in loss of zoom capability.

11

### NOTE:

Before installing the lens port and checking operation, make sure the teeth on the Gear Sleeve mesh with the teeth on the housing Drive Gear (Fig. G). When the port is installed, it will lock the Gear Sleeve in place. After installing the port, rotate the housing Zoom Control Knob to see that the Gear Sleeve is properly rotating the lens Zoom ring.

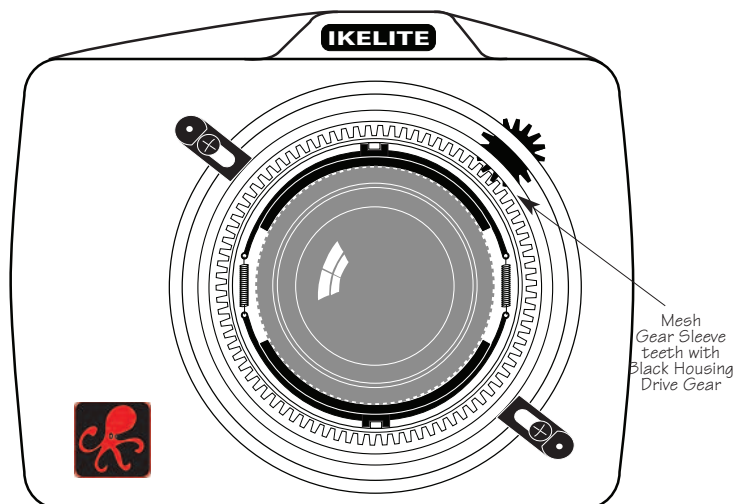
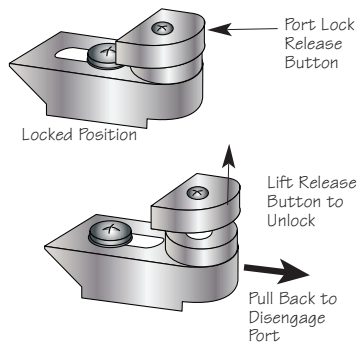

Figure G

12

## Installing the Port

There are two port locks on the front of the housing (See housing front). Each port lock has a Release Button. Lift the release button and slide each Port Lock away from the port opening. In the unlocked position, the Release Button will remain in the up position as shown.



To prepare the port for installation, remove the port o'ring and lightly lubricate it. The port seal is a side-to-side seal and requires the o'ring to be lightly lubricated for easy installation. Put a small amount of lubricant on your fingers and pull the o'ring through your fingers to lightly lubricate it. Do not stretch the o'ring. Check that the lip of the port where the o'ring fits and the sealing surface on the housing are clean. Place the port, with o'ring, into the housing port opening. Press down on the port firmly and evenly until you feel the port slide into place. Continue to push down on the port and push each port lock forward until it clicks into place. It may help to slightly rotate the port as you push in on each port lock. When the port lock clicks into place, the Release Button will drop down against the port lock.

Check around the perimeter of the port seal to see that the o'ring is properly sealed and not extruded (**Page 14 - Fig. 2**).

13

## Using External Strobes

This housing has Conversion Circuitry built into the housing. When used with Ikelite DS Substrobes the Conversion Circuitry provides real Nikon iTTL flash exposure with over and under-exposure compensation from +1 1/3 to - 1 1/3 f-stops in 1/3 stop increments.

### NOTES:

- Flash Exposure Compensation set in the camera will be added or subtracted from the compensation set on the housing conversion circuitry in iTTL.
- Balanced Fill Flash cannot be used.
- Do not use red-eye reduction setting

The Conversion Circuitry also offers Manual exposure control with 3 1/2 f-stops of under-exposure control in 1/2 stop increments.

The Conversion Circuitry is powered by the Ikelite DS Substrobe when connected to the housing with the #4103.51 single or #4103.52 dual sync cord.

See page 19 for DS Substrobe compatibility with the Conversion Circuitry.

## Using Ikelite Non-DS Substrobes (Substrobe 50, 100A, 200, 400) and NON-Ikelite Strobes with this Housing.

The Conversion Circuitry is automatically disabled when used with a Non-DS or Non-Ikelite Substrobe. These Substrobes can be used in their manual mode utilizing any power settings provided on the Substrobe.

15

## Installing the Port cont.

### To Remove Port

To remove the port, lift up on each Release Button and slide the port lock away from the port.

### Port Seal Inside View

If the port is installed before the camera is inserted into the housing, look from the inside of the housing at the port seal. Check to see that the o'ring is properly seated as shown in figure 1 and not extruded as shown in figure 2.

Fig. 1

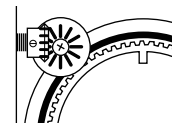
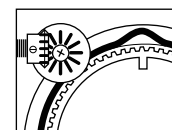

Fig. 2



### Caution:

After installing the port, turn the Zoom Control knob on the housing. If the Zoom Control is difficult to turn, the gear sleeve may be warped. If necessary, reduce or omit any rubber installed on the Zoom Clamp (Fig.F on pg.10). *If the Zoom Clamp is still warped, use of the #5509.28 package may be required. (See page #8)*

### NOTE: (lens ports)

A lens port must be secured to the housing before entering the water. Ikelite DSLR housings DO NOT come with a lens port. You must select the correct port for each lens you will be using underwater. For complete lens/port information and compatibility with your Ikelite system, go to [www.ikelite.com](http://www.ikelite.com)

14

## Using External Strobes Cont.

### Using the Conversion Circuitry (Set DS Substrobe to TTL mode)

#### • Mode and Compensation Dial

Note that the TTL compensation values are located in the yellow band. Manual compensation values are located in the black band. Rotate the Dial to switch between TTL and Manual Modes.

#### • TTL Mode

TTL Mode compensation values are indicated in the yellow band. Place the Setting Indicator to TTL for NO Compensation. Rotate the Dial either

direction to select +/- compensation. Place the Setting Indicator to the desired compensation value. Note that in TTL compensation values are in 1/3 f-stops.

#### • Manual Mode

Manual Mode compensation values are indicated in the black band. Rotate the Dial to place the Setting Indicator to the desired compensation value. Note that in Manual Mode compensation values are in 1/2 f-stops from (F) full power to -3 f-stops.

(Set DS Substrobe to TTL mode)

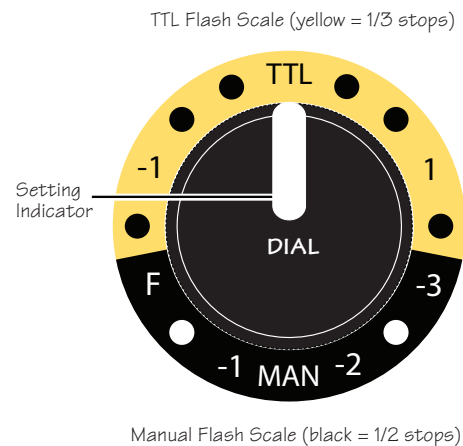

16

## Using Ikelite DS Digital Strobes

For the best underwater photographic results, we recommend adding an external DS-digital strobe connected to the housing with a #4103.51 TTL Sync Cord and a SA-100 Ball/socket arm (Page #18).

Ikelite DS series Substrobes are industry favorites for their warm, even coverage and lightning fast recycle time. Being farther from the camera lens, the optional DS Substrobes aids in reducing the illumination of particles in the water and helps to eliminate backscatter. When used in conjunction with the EV-Controller, the DS51 Mode switch is set to the TTL setting and the EV-Controller provides ten power settings in half-stop increments.

### Substrobe DS51

The Substrobe DS51 covers the equivalent of a 28mm lens. The DS51's intensity and angle of coverage make it equally suited for macro and general photography.



**Substrobe DS51**  
Actual Size  
8 cm dia x 12 cm  
3.2" dia x 4.7"

17

## NOTE: DS Substrobe Update information

### DS50 Substrobes

- DS50 SubStrobes with a Serial Number below 63,850 can not be updated to operate with the Conversion Circuitry.
- DS50 SubStrobes with a Serial Number between 63,850 and 69,999 operate with the Conversion Circuitry, but require an update to provide optimum performance.
- DS50 Substrobes with a Serial Number of 70,000 or higher, or with one of the two following labels in the battery compartment provide optimum performance with the Conversion Circuitry and do not need an update.



### DS125 Substrobes

- DS125 Substrobes with a Serial Number below 2,500 must be updated to operate correctly with the Conversion Circuitry.
- DS125 Substrobes with a Serial Number between 2,501 and 4,900 will operate with the Conversion Circuitry, but require an update to provide optimum performance.
- DS125 Substrobes with a Serial Number of 5,000 or higher, or with one of the two following labels in the battery compartment, provide optimum performance with the Conversion Circuitry and do not need an update.



### To Update Your Substrobe:

Send to the Ikelite address on the back page of this manual or contact Ikelite for more information.

19

## Substrobe DS160

The Substrobe DS160 covers the equivalent of an 18mm lens or 100 degrees w/diffuser installed. It is the ideal choice when using accessory wide angle lenses greater than 28mm. It also features a 1.5 second recycle time and 225 flashes per full charge.

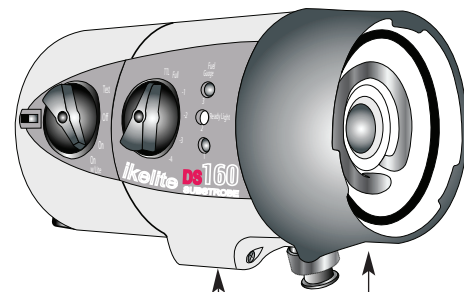

**Substrobe DS160**  
Actual Size  
9.6 cm dia x 17.9 cm  
3.75" dia x 7"

### SA-100 Ball/Socket Arm

The SA-100 system #4086.61 with its 1" diameter ball is ideal underwater. The #9571.3 extended stem mount allows easy attachment of the EV controller or flashlight mount, and drops right into the release handle. The arm system allows easy strobe placement from macro close-up to wide angle without changing aim of the Sensor. The complete system removes with a push of the handle button.

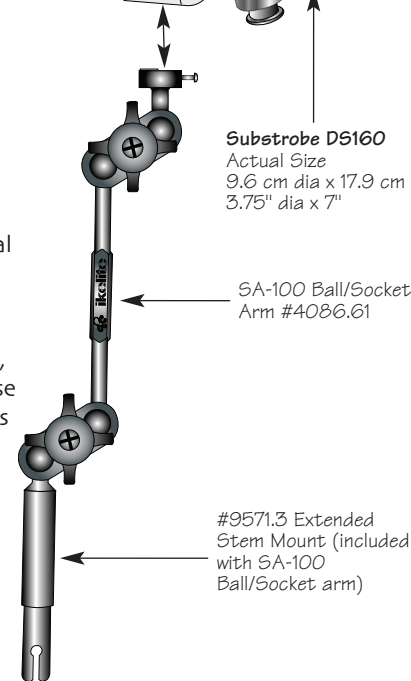

SA-100 Ball/Socket Arm #4086.61

#9571.3 Extended Stem Mount (included with SA-100 Ball/Socket arm)

18

## Recommended Strobe Packages

**Substrobe DS-51 Package #3944.51** includes #4086.61 Arm System with Ikelite TTL sync cord.

**Substrobe DS-160 Package #3944.90 (Recommended)** includes #4086.61 Arm System and 1.5 hour Smart Charger with Ikelite TTL sync cord.

**Substrobe DS-200 Package #3944.60** includes #4085.26 Arm System and 1.5 hour Smart Charger with Ikelite TTL sync cord.

## Please Read If Using an EV-Controller

**TTL flash control is not available when using an EV-Controller, and therefore an EV Controller is not recommended for use with this housing.**

**NOTE:** The EV-Controller cannot be used as a slave. If hard-wired to the housing, set the EV-Controller to Non pre-flash.

Complete information regarding Ikelite products and optional accessories available at [www.ikelite.com](http://www.ikelite.com)

20

## Lubricants

1. Ikelite provides silicone lubricant with the housing. We recommend that you use only Ikelite lubricant. Other brands may cause the o'ring to swell and not seal properly.
2. Use only enough Ikelite lubricant to lightly cover control shafts and o'rings. Wipe off any excess lubricant with a clean cloth. Lubricant is not a sealant and is used to reduce friction. Excessive lubricant can collect sand and dirt which may interfere with proper sealing.

**Note:** Lubricant is not needed on the main housing o'ring to maintain a housing seal, however, lightly lubricating this o'ring can extend it's life and aid in seeing a good housing seal. Too much lube can attract debris increasing the potential for a leak.

**CAUTION:** *Never use spray lubricants as the propellant ingredient can cause the plastic housing to crack.*

## Pre-Dive Your System

It is recommended that you take the complete system into a swimming pool before use in open water. This will give you a chance to become familiar with the handling and operation of your housing and strobe(s).

21

## Control Maintenance

Ikelite controls are designed to provide years of reliable service with minimal maintenance.

1. Push button controls require no maintenance other than rinsing in fresh water after saltwater use. If a push button control becomes difficult to push or if it sticks when depressed, soak the housing in luke warm fresh water. After a few minutes, operate the push button. If this does not correct the problem, return the housing to Ikelite for maintenance.
2. Some of the controls have long shafts. These controls can be pulled out, exposing the shaft (see Diagram B on page #24). To lubricate the control, gently pull on the knob until the stainless steel shaft is exposed. Lightly lubricate the shaft, then move the shaft in and out several times. This will lubricate the x-ring in the Ikelite control gland. This should be done before using the housing after a prolonged storage period, or once a week when the housing is in constant use.
3. Some of the controls have a short shaft and cannot be pulled out exposing the shaft for lubrication. In the unlikely event one of these controls sticks or becomes difficult to operate you can remove the control from the housing and lubricate it, or return the housing to Ikelite for maintenance. To remove the control (see Diagram A on Page #24), loosen the set screw in the knob (allen wrench required); remove the knob. If there is salt or dirt build-up on the exposed control shaft, clean the shaft. Open the housing and gently slide the control shaft out of the control gland. Clean and lightly lubricate the shaft, including the end of the shaft.

23

## Optional Accessories

### Lead Weight #0906.58

The buoyancy of the system will depend on the size and number of strobes used as well as the weight of the camera. Ideally the system should be slightly negative in the environment in which it will be used. If you need to add weight to the system, an optional lead weight is available. To add the lead weight remove the (2) screws from the bottom of the aluminum tray. Place the lead weight into the pocket of the aluminum tray and reattach.

While both the Port and Back o'rings should last quite some time, it is best to carry a spare, in case one becomes damaged or lost.

### #5512.69 O-ring Kit (Recommended)

#5512.69 O-ring Kit includes:

Ikelite Lube #0184.1

Port O'ring #0105

Housing Back O'ring #0132.61

## Storing the Housing

When the housing is going to be stored for a prolonged period it should be soaked in a mild soap solution, rinsed and dried thoroughly. Remove the back and port from the housing. Remove the back and port o'rings, lightly lubricate them and place them in a plastic zip-lock bag. Place the plastic bag inside the housing for storage. Operate the push buttons periodically.

22

## Control Maintenance Cont.

3. Slide the shaft back into the control gland and gently slide it back and forth a few times without fully removing the shaft from the gland. Replace the knob noting the flat area on the shaft. The set screw in the knob should tighten down against the flat area on the control, so the knob does not turn on the shaft.

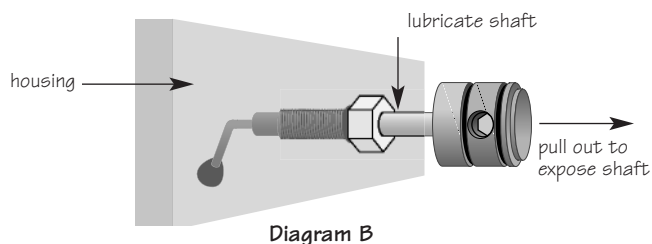
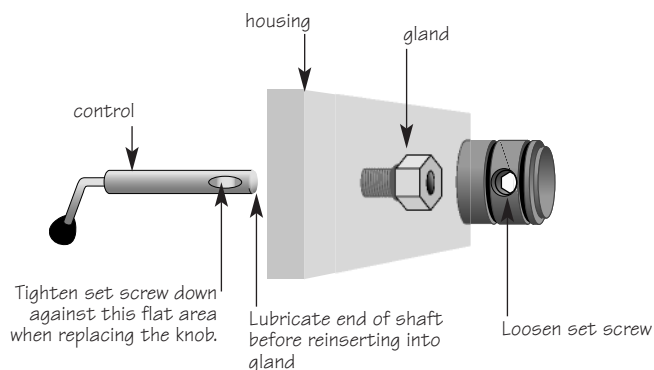

24

## General Housing Maintenance

Your Ikelite Housing should be given the same care and attention as your other photographic equipment. In addition to normal maintenance, we recommend your housing be returned to Ikelite (every 2-3 years or 50 dives), to be checked and pressure tested.

1. **Do Not** leave the camera and housing in direct sunlight for prolonged periods. Heat may damage the camera.
2. **Do Not** ship the camera in the housing.
3. Before using the housing, always check the tightness of the **set screw** in each control knob. Check each **control gland** penetrating the housing to make sure they are tight. There is a slight chance that either could vibrate loose during travel.
4. Keep the back and port o'ring clean and lightly lubricated. To lubricate, remove the o'ring from the back. Put a small amount of Ikelite lubricant on your fingers. Pull the o'ring through your fingers to apply a light coating of lubricant. Only apply enough lubricant to make the o'ring feel slick. **Do Not stretch the o'ring.** This light coating of lubricant will help to keep the o'ring from drying out and will help to show a dark sealing line when the housing back is properly sealed.
5. Keep the area where the o'ring fits and the sealing surface clean.
6. Rinse the housing exterior thoroughly in fresh water after each salt water use. Depress push buttons several times during rinse. Dry with a soft cloth. Dry port to eliminate water spotting. After several uses in salt water, soak the housing in a mild soap solution, rinse, and dry.
7. Although not recommended, if it is necessary to remove a housing push button, **Do Not** re-use the E-clip. Contact Ikelite for replacement E-clips (part #0319.12).

**CAUTION: Never use spray lubricants as the propellant ingredient can cause the plastic housing to crack.**

25

## Photo Tips

1. The number one rule in underwater photography is to eliminate as much water between camera and subject as possible. Get as close as you can to the subject, then use the zoom. If you are using flash, subjects beyond 6 feet (1.8m) will not have much color, regardless of the strobe's power.
2. Many digital cameras have a slight lag time between when you press the shutter release button and when the camera actually takes the picture. It only takes a slight amount of pressure to operate the shutter. If the shutter doesn't trip immediately, don't push down harder on the shutter control, as you may damage the camera. Hold the camera steady a second or two after pressing the shutter release button.
3. Do not shoot down on subjects as they will quite often blend into the background and be difficult to see in the photograph. Shoot subjects straight on, or shoot up at a slight angle using the blue water as a contrasting background.
4. Underwater flash is used to restore the warmer colors filtered out by the water as well as to illuminate the subject.
5. For balanced lighting, meter the background and set the camera aperture accordingly. Use TTL, adjust the strobe's power settings, or move the strobe closer or farther away to properly expose the subject with the chosen camera aperture.
6. Avoid shooting into the sun. This can cause unwanted reflections or underexposed subjects.

27

## General Tips

1. You should completely assemble and test your system in a swimming pool before using it in openwater.
2. It is a good idea to start each photo dive with a fully charged battery in the camera and strobe(s).
3. As soon as you enter the water, take a moment and check the housing to see that it is properly sealed. Next, check to see if there are any bubbles on the face of the port. If there are, take your fingers and remove them. If there are bubbles on the lens port they can produce soft focus spots in your photographs.
4. Set Image Resolution to the Highest JPG format available or RAW. Higher resolution settings are required for printing. High resolution images can easily be reduced in size with software and retain their original quality. A Low resolution image can be enlarged with software but much of the quality will be lost.
5. ISO 100 and "center-weighted averaging" metering are recommended.
6. Digital images are usually transferred to the computer where their appearance can be fine tuned. Many image manipulation programs make you think you can magically correct any image taken and make a good picture. One thing to be aware of is that if an image is overexposed, some of the color information in the file is missing. If the color is missing, you cannot adjust it. If images are underexposed, the color and detail may be there, however it is just dark, so you can adjust it to some degree. If exposure error occurs, it is better to have the image slightly underexposed rather than overexposed.

26

## Ikelite Limited Warranty

All Ikelite products are warranted against any manufacturing defects for a period of one year from the original date of purchase. Defective products should be returned prepaid to Ikelite. Ikelite will, at its discretion, repair or replace such products, and will return to customer prepaid. All other claims, of any nature, including but not limited to bulb failure are not covered. Except as mentioned above, no other warranty expressed or implied, applies to this Ikelite product.

## Returning Products for Service

Ikelite is most interested in performing any service to assure that all products perform as intended. For repair or service, return the product to the address below with your name, address, phone number and a brief description of the problem. Evidence of purchase date must be provided to obtain warranty service. Normal service turnaround time is approximately 2-3 weeks.

Ikelite Underwater Systems  
50 W 33rd Street  
Indianapolis, IN 46208 USA

When returning products, send "attn. Repair Dept."

317-923-4523

"general questions" e-mail: [ikelite@ikelite.com](mailto:ikelite@ikelite.com)  
[www.ikelite.com](http://www.ikelite.com)