



Underwater Housing for Panasonic Lumix DMC-ZS60, DMC-TZ80

Product Number 6170.60

Product Registration

Please register your product at ikelite.com within 15 days of purchase. Our product registration database is the best way for us to get a hold of you in the event of a product update or notice.

About this Product

Thank you for your purchase of Ikelite equipment. Please read this instruction manual completely before attempting to operate or dive with this product. Please visit ikelite.com to register your product to receive information on any updates, notices, or recalls pertaining to your equipment.

Included in the Box

- Housing
- O-ring # 0109 (installed)
- Vinyl port cover # 0200.08 (installed)
- Silicone lubricant

Important Notices

- » **Never leave a housing in a rinse tank, even if it is the only system in the tank. The vast majority of catastrophic floods happen when the user walks away from a housing while it is in the rinse tank.**
- » **To prevent salt build-up and sticking controls, submerge the empty housing in clean, freshwater. Operate the controls several times each while underwater to flush out any residue.**
- » **Do not use alcohol, cleaning agents, spray lubricants, Rain-X, or other solvents on the housing or lens port. Use of an incompatible chemical compound can damage the plastic and o-rings, and may result in leaking.**

Accessory Port

- » **Do not remove the Accessory Port Hole Plug unless you are installing a compatible accessory.**

Your housing features one 1/2-20 threaded Accessory Port which may be used for attachment of factory optional or aftermarket housing accessories. Visit **ikelite.com** for an updated list of factory optional accessories.

Contents

Product Registration	1
About this Product	2
Included in the Box	2
Important Notices	3
Accessory Port	3
Getting to Know Your Housing	5
Setting Up Your Camera	7
Pre-Installation Checklist.....	7
Setting Up Your Housing	7
Opening the Housing.....	7
Inserting the Camera.....	8
Closing the Housing.....	8
Final Check.....	9
Entering the Water.....	9
Setting Up An External Strobe	10
About the Built-In Flash.....	10
Attaching a Fiber Optic Cord.....	10
Maintenance	11
Post-Dive.....	11
Travel and Storage.....	12
Troubleshooting	12
Limited Warranty	14
Service and Repairs	15
Contact Us	16

Getting to Know Your Housing

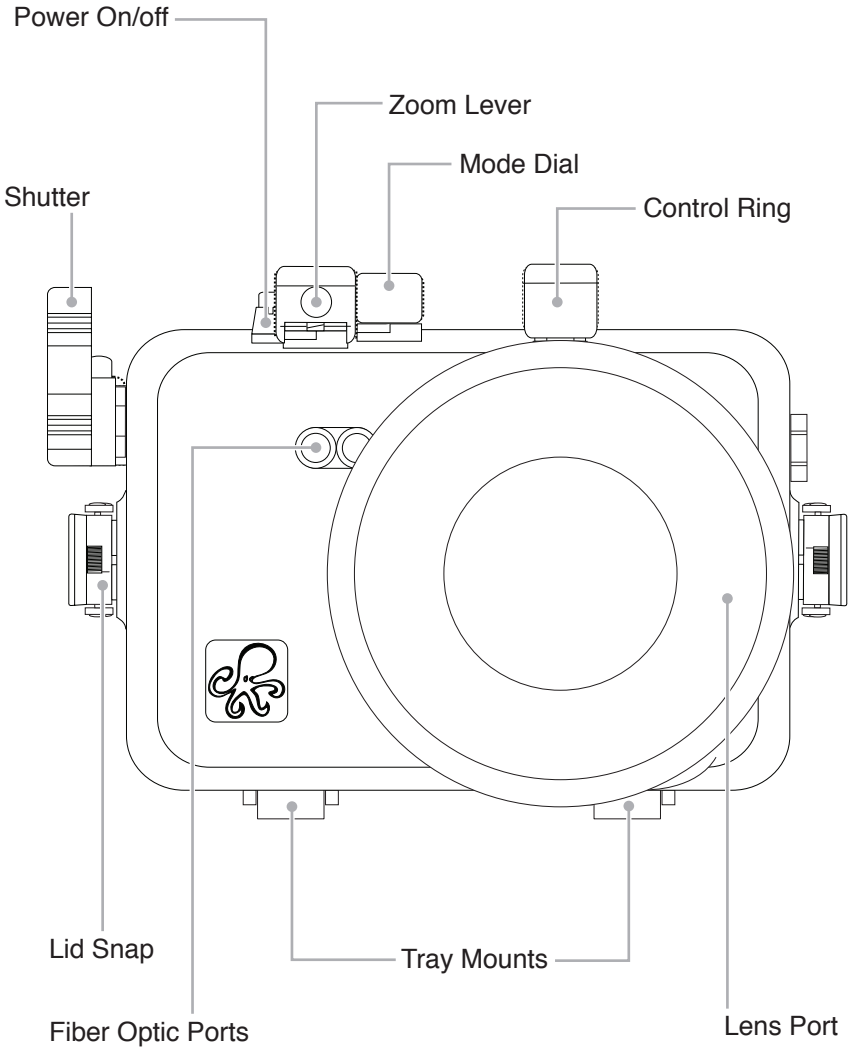

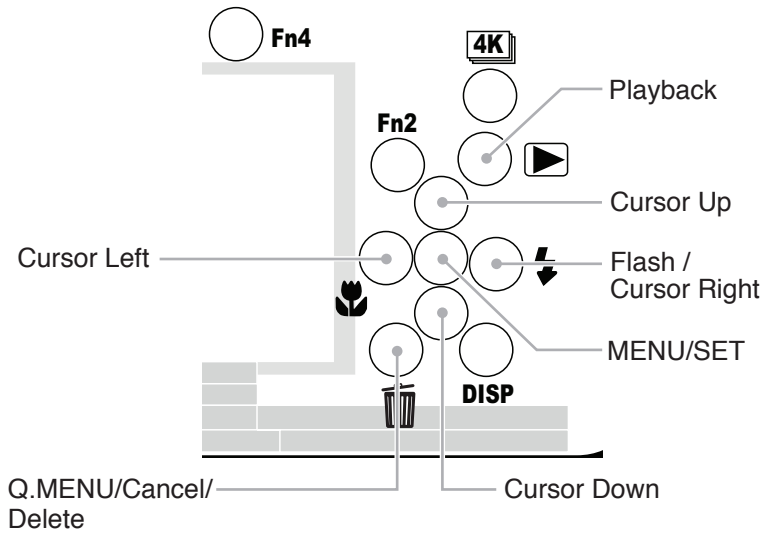
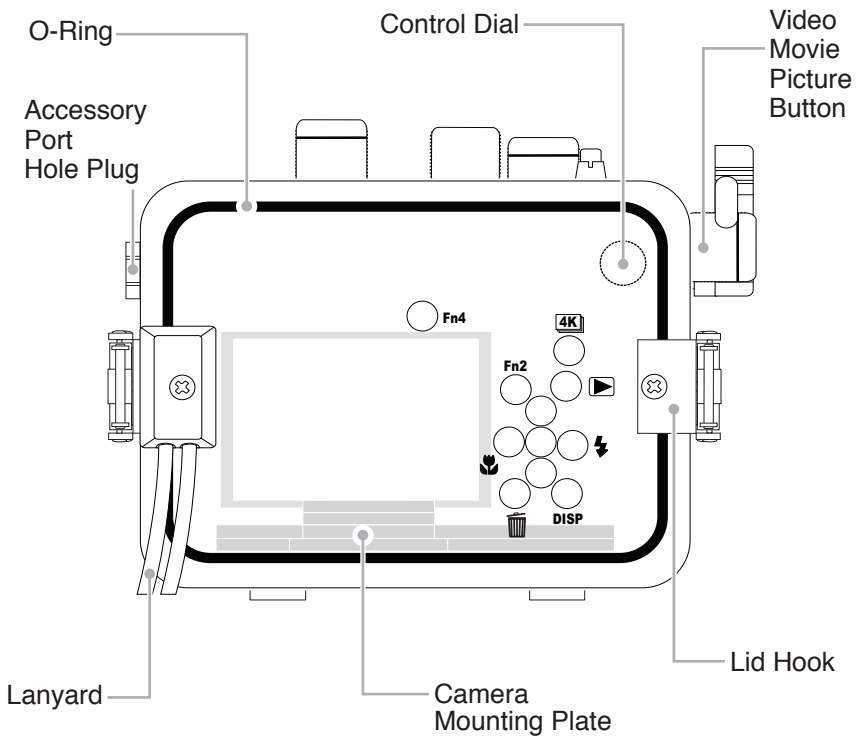

Setting Up Your Camera

Pre-Installation Checklist

1. Insert a fully charged camera battery.
2. Insert a properly formatted memory card.
3. Set AF Assist Lamp and Red-Eye Removal to “OFF.”
4. Set Eye Sensor LVF/Monitor Switch to “MON.”
5. Set Touch Settings - Touch Screen to “OFF.”
6. Check the Picture Size and Quality.

Setting Up Your Housing

Opening the Housing

1. Push the lid snap lock forward and start to lift the curved end away from the housing.
2. Lid snaps are designed to provide enough force to compress the o-ring for a proper seal. Keep firm pressure against the lid snap while lifting it away.

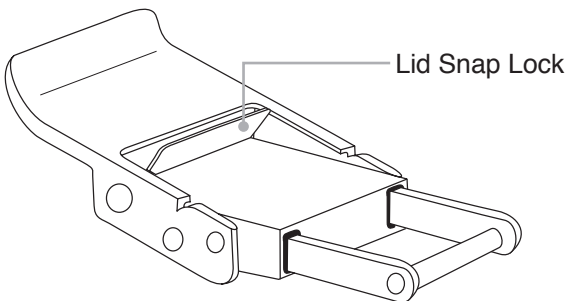

3. Repeat with remaining lid snaps.
4. Remove the housing back.

Inserting the Camera

1. Remove any lanyard or neck strap which may be attached to the camera.
2. Remove the camera mounting plate from the housing.

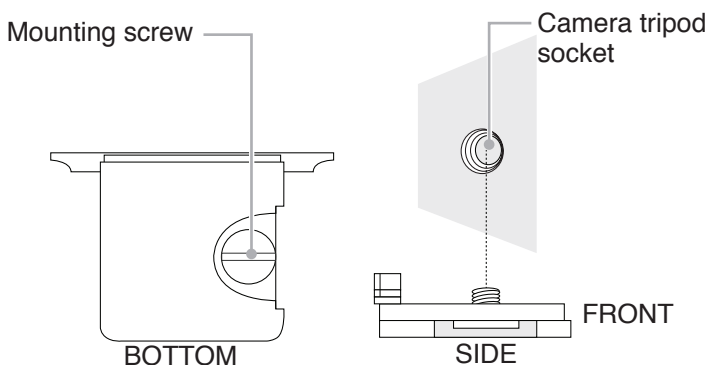

3. Line the mounting screw up with the camera's tripod socket. Use a coin or flat head screwdriver to tighten the mounting plate to the camera.
4. Pull out on the housing control knobs to move them out of the way.
5. Insert the mounting plate into the slot on the inside bottom of the housing. Push the camera all of the way forward until the back of the mounting plate is flush with the back of the housing mount.
6. If using an external strobe, raise the camera's built-in flash. Once the camera is closed in the housing, the flash cannot be raised.

Closing the Housing

1. Make sure the o-ring is clean and in its proper location on the back of the housing. The main o-ring does not require lubricant to make a seal.
2. Place the back onto the housing front.
3. Make sure no controls or cords are interfering with the o-ring or the back of the housing.

4. Place each lid snap into the corresponding hook on the housing back.
5. Push the lid snaps towards the housing until they are flat against the housing and the lock has engaged. Close opposing lid snaps at the same time.
6. Check the o-ring seal. The o-ring should form a uniform, solid line around the back of the housing. There will be a small, even gap around the housing between the housing back and the housing front.

Final Check

1. Re-check the o-ring seal. The seal should form an even, solid line around the back of the housing.
2. Turn on the camera and check all control functions.
3. Make sure that the camera can obtain focus and take a photo.
4. Check battery life and open storage space on your memory card.
5. Check the flash, if using.
6. Submerge the housing in a fresh water tank dedicated to underwater photography equipment. Visually confirm that there are no signs of water intrusion or a steady stream of bubbles coming from one of the housing seals.

Entering the Water

1. If possible, we recommend entering the water without your housing to ensure that you are comfortable and your life-saving equipment is in working order. Once you are stable, have someone pass your camera housing to you.

2. Submerge the housing at the surface of the water and visually confirm that there are no signs of water intrusion or a steady stream of bubbles coming from one of the housing's seals. If water does appear to be entering the housing, point the lens port downward and return the housing to the surface as quickly as possible. Please observe all necessary safety precautions. NEVER ascend faster than accepted safety limits.
3. Use your hand to gently flush away any small bubbles that may be on the face of the lens port. Bubbles will produce soft focus spots in your photo or video.

Setting Up An External Strobe

About the Built-In Flash

Due to the opaque housing design, the internal "built-in" flash can only be used to trigger external fiber optic strobes. To shoot flash photography underwater, an external strobe must be connected to the housing and then triggered via fiber optic cord. Always extend the flash BEFORE closing the camera inside the housing.

We recommend attaching an external strobe for the optimal color and clarity in a wide variety of shooting situations, including daylight photography.

Attaching a Fiber Optic Cord

1. Check the end of the fiber optic cord to ensure that it is clean and smooth.
2. Ensure that the fiber optic cord o-ring is in place. This o-ring does not provide waterproofing, however it does keep the fiber optic cord in place.

3. Attach one end of the fiber optic cord into one of the fiber optic ports on the front of the housing. The connector is a press-fit into the fiber optic port.

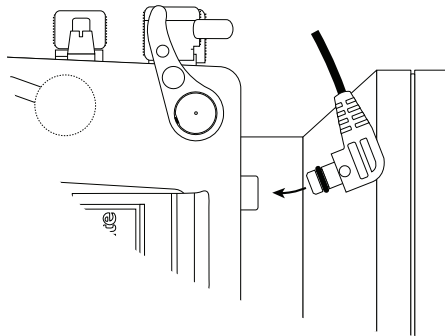

4. Attach the other end of the fiber optic cord to a compatible strobe.
5. Set the strobe to the appropriate setting based on manufacturer recommendations.
6. Turn the camera on and set it to always fire the flash.
7. Turn the strobe(s) on.
8. Take a test photo to ensure that your strobe(s) are functioning properly.

Maintenance

Post-Dive

1. Rinse the housing in fresh water. Rotate the housing's controls and press each button while submerged in fresh water to flush out any salt or debris to ensure smooth operation on future dives.
2. NEVER leave your housing in the fresh water rinse tank. Collisions with other peoples' gear can cause scratches or damage to your equipment.
3. Stow the housing in a shaded place where it is protected from impact or overheating. If no shade is available, we recommend covering the housing with a towel or cloth.

4. Check the memory card capacity and battery life of your camera and strobe(s). Recharge as necessary.
5. Always re-check o-ring seal after opening the housing.

Travel and Storage

1. Remove the camera from the housing for travel or storage.
2. Check the main housing o-ring.
3. Close the empty housing and submerge in lukewarm fresh water. While submerged, rotate each control and depress each button to flush out any salt or debris.
4. Remove the housing from water and rinse with running water.
5. Do not rinse the inside of the housing or submerge the open housing in water. If the inside of the housing needs to be cleaned, wipe with a clean, slightly damp cloth.
6. Dry the housing with a clean, lint-free cloth.
7. Store in a cool, dry place.
8. Like regulators and other pressure-sensitive equipment, we recommend careful care and cleaning along with annual replacement of the factory seals.

Troubleshooting

Water enters the housing

- Re-clean and re-install the main o-ring.
- Take the housing underwater without a camera installed to ensure that the leaking has been corrected.

Photos are over-exposed (too light)

- Adjust aperture (smaller), shutter speed (faster), or ISO (lower) setting.
- Move lights(s) farther away from your subject.
- Adjust exposure compensation in the camera.
- Adjust lighting power.

Photos are under-exposed (too dark)

- Adjust aperture (larger), shutter speed (slower), or ISO (higher) setting.
- Move light(s) farther away from your subject.
- Adjust exposure compensation in the camera.
- Adjust lighting power.

Strobe will not fire

- Turn on strobe.
- Make sure that the camera's flash is set to fire on every photo.
- Check that the fiber optic cord is attached.

Buttons are stuck

- Soak the housing in lukewarm fresh water. Depress each button several times while the housing is submerged.
- Apply lubricant to the button. Press the button several times to distribute the lubricant.
- Return the housing for service.

Button(s) or control(s) do not line up

- Ensure that nothing is preventing the camera from going into the housing.

- Push the camera mounting plate forward until it is flush with the housing base plate.

Camera is not functioning normally underwater

- Ensure that the camera mounting plate is pushed all of the way into the housing mounting plate.
- Check each housing control while underwater to ensure that they are disengaged. An inadvertently engaged control may limit functioning of the camera.
- Check that the zoom control is returned to the center position.

Backscatter or “snow” in images

- Position strobes or lights farther away from your lens and at a slight angle.
- Avoid using strobes in extremely low-visibility conditions.

Limited Warranty

This Ikelite product is warranted against any manufacturing defects for a period of two (2) years from the original date of purchase. Defective products should be returned to Ikelite postage paid. Ikelite will, at its sole discretion, repair or replace such products, and will return to customer postage paid. All other claims of any nature are not covered. Except as mentioned above, no other warranty expressed or implied applies to this Ikelite product.

Service and Repairs

Ikelite is most interested in performing any service to ensure that all products perform as intended. Evidence of purchase date must be provided to obtain warranty service. No prior authorization is required. You may return directly to us or through your dealer. Please include a brief description of the problem, any relevant email correspondence, and/or description of the service request. Always include name, shipping address, email address, and phone number inside of the package. Send postage paid to:

Ikelite Underwater Systems
Attn: Service Department
50 West 33rd Street
Indianapolis, IN 46208 USA

For the separate international customs documentation form that you complete to accompany the shipment, please state or designate that the enclosed products were originally manufactured in the USA and are being returned to the manufacturer for repair service. Value of the equipment listed for customs purposes should be zero.

Contact Us

If you have any questions about your product or need advice on getting the images you want, please get in touch with us and we'll do everything we can to help you capture your unique perspective.

Ikelite Underwater Systems
50 W 33rd St
Indianapolis, IN 46208 USA
(317) 923-4523
ikelite@ikelite.com