



# Digital Housing Instruction Manual **6146.02 for Canon G1 X Mark II**

Thank you for your purchase of Ikelite equipment. Please read this instruction manual completely before attempting to operate or dive with this product. Please refer to the back page of this manual to register your Ikelite product.

## Table of Contents

<b>Preparation</b> .....	P. 3
<b>Specifications</b> .....	P. 4
<b>What's in the Box</b> .....	P. 4
Parts of the Housing - Front View .....	P. 5
Parts of the Housing - Back View .....	P. 6
<b>Housing and Camera Setup</b> .....	P. 7
STEP 1 - Attach Tray and Handle to the Housing .....	P. 8
STEP 2 - Initial Camera Settings .....	P. 8, 9
STEP 3 - Opening the Housing .....	P. 9
STEP 4 - Attach Hotshoe to Camera .....	P. 10
STEP 5 - Attach Camera to Mounting Tray .....	P. 11
STEP 6 - Attach the Step Ring Gear .....	P. 12
STEP 7 - Installing Camera in Housing .....	P. 13
STEP 8 - Closing the Housing .....	P. 13
STEP 9 - Final Check.....	P. 14
<b>Usage</b> .....	P. 14
<b>Strobe Use and Compatibility</b> .....	P. 14
Strobe Compatibility .....	P. 14
Ikelite Housing Conversion Circuitry .....	P. 15
Attaching a Sync Cord to the Housing .....	P. 15, 16
Using Strobes with a Fiber Optic Connection .....	P. 16
Diffuser and Deflector Installation / Usage.....	P. 17
Attaching an Ikelite Strobe Arm to the Housing Handle..	P. 18
Entering the Water .....	P. 19

## Table of Contents - continued

<b>Recommended Accessories</b> .....	P. 19, 20
<b>Maintenance</b> .....	P. 21 - 24
<b>Photo Tips</b> .....	P. 25
<b>Troubleshooting</b> .....	P. 26 - 28
Zoom Control .....	P. 28
<b>Spare Parts</b> .....	P. 29
<b>Customer Support</b> .....	P. 30
<b>Limited Warranty</b> .....	P. 30
<b>Returning Products for Service</b> .....	P. 31
<b>Product Registration</b> .....	Back Page

## Preparation

This product has been water pressure tested at the factory and is depth rated to 200 ft (60 m). Thoroughly inspect and immerse the empty housing completely in water before installing a camera. If any fogging occurs or droplets of water enter the housing, do not install a camera. Clean the main housing o-ring and retest to make sure that it is watertight. Refer to the Troubleshooting section, page 26.

Please read your camera manual thoroughly to have a full understanding of each camera function.

If you are new to underwater photography, be sure to read the Photo Tips section, page 25.

## Specifications (no camera installed)

<b>Controls</b>	.....All important camera functions accessed
<b>Buoyancy</b>	.....Nearly neutral in saltwater
<b>Depth Rating</b>	.....200 ft (60 m)
<b>Strobe Connections</b>	.....Ikelite Digital TTL ICS-5 5-pin Electrical .....Bulkhead plus TTL circuitry compatible with .....current model Ikelite DS strobes and Fiber .....Optic Ports.
<b>Use Built-in Flash</b>	.....Yes
<b>Tray and Handle Weight</b>	.....11.5 oz (327 g)
<b>Main O-Ring</b>	.....0110
<b>Housing Dimensions</b>	.....Dimensions 7.4 x 6.4 x 7.3 in (188 x 157 x .....185 mm)
<b>Housing Weight</b>	.....4.7 lb (2.1 kg)
<b>Housing Material</b>	.....Polycarbonate front, acrylic back

## What's in the Box

- Housing
- Tray with Quick Release Handle
- Port Cover
- Flash Diffuser
- Flash Deflector
- Step Ring Gear with set screws
- Waterproof Bulkhead Cap (on External Strobe Connector)
- Silicone 1cc Lubricant Tube
- Allen wrench for control knob set screws
- Step Ring Gear with 3 small set screws installed, 3 extra small set screws and small allen wrench (in a bag inside housing)

## Parts of the Housing - Front View

*Housing controls are provided for all camera functions except the flash up switch. When using the built-in camera flash, it must be extended BEFORE placing the camera in the housing.*

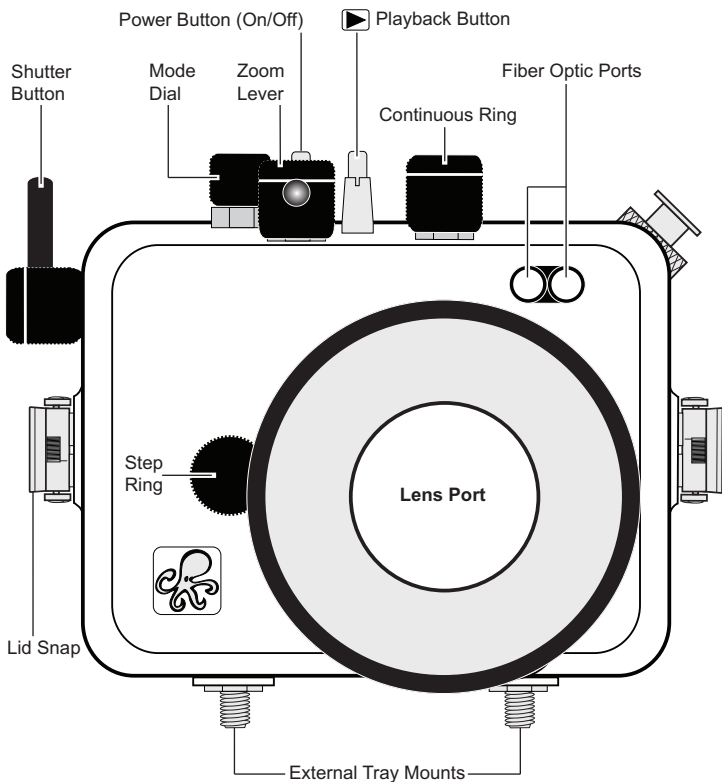

## Parts of the Housing - Back View

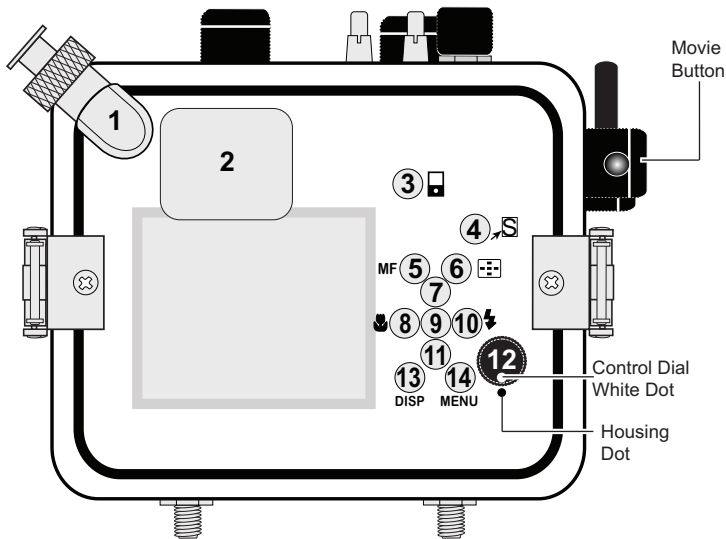

- |                                    |                                |
|------------------------------------|--------------------------------|
| 1. External Strobe Connector & Cap | 8.   Macro / Left Button       |
| 2. Conversion Circuitry            | 9.  FUNC./SET Button           |
| 3.  Mobile Device Button           | 10.   Flash / Right Button     |
| 4. <b>S</b> Shortcut Button        | 11.   ISO / Down Button        |
| 5. <b>MF</b> Manual Focus          | 12. * Control Dial             |
| 6.  AF Frame Selector              | 13. <b>DISP</b> Display Button |
| 7.   Exp. Comp. / Up Button        | 14. <b>MENU</b> Button         |

\* Control Dial: Note that a small section of the rubber disc is missing at the end of this control. This is normal and allows the user to completely disengage the control from the camera when not in use. To disengage Control Dial from camera, rotate Dial to 6 o'clock position and line up Control Dial White Dot with Housing Dot. Rotate Control Dial White Dot to 12 o'clock position when attaching or removing Housing Back.

## Housing and Camera Setup

### STEP 1 - Attach Tray and Handle to the Housing

Using a 9/16" open/box end or socket Wrench (*not supplied*), firmly tighten the External Tray and Spacer to the Housing Base using the two 3/8-16 Nuts supplied in the accessory package. One side of the Spacer has an adhesive backing. Remove the Protective Film to adhere the Spacer to the Tray.



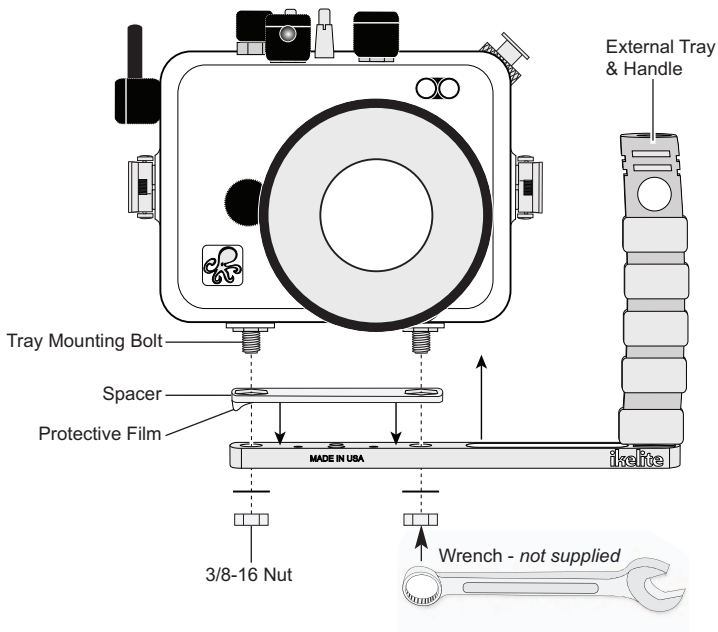

**Note:** Tray and Handle may be attached before or after the camera is secured in the Housing. We recommend attaching it immediately to avoid scratching table tops with the Tray Mounting Bolts.



## STEP 2 - Initial Camera Settings

Setup your camera for underwater use and then adjust your settings once underwater.

### Initial Camera Setup (before placing camera in housing)





- Insert a fully charged camera battery.
- Set Mode Dial to “Av” Aperture Priority, or “M” Manual Mode if shutter speeds faster than 1/60th second are required.
- In  **MENU:**
  - Set AF Frame to “1-point” and Digital Zoom to “Off.”
  - Set AF-Point Zoom to “Off” and Set Servo AF to “On.”
  - Set Continuous AF to “Off” and AF-assist Beam to “Off.”
  - In the **Flash Control Built-in Flash Settings Menu**, set Flash Mode to “Auto”, Shutter Sync. to “1st-curtain”, Red-eye Corr. and Red-eye Lamp to “Off.”
  - Set Review Image after Shooting to “8 sec.” and Display Info to “Off.”
  - Set Blink Detection and Night Display to “Off.”
- In  **MENU:**
  - Set Date/Time and Time Zone.
  - Set Eco Mode to “Off.”
  - In the **Power Saving Menu**, set Auto Power Down to “Off” and Display Off to “3 min.”
  - Set Touch Operation to “Off.”
  - Insert and Format a compatible memory card.
- In **FUNC./SET MENU:**
  - Set DR Correction to “Off” and White Balance to “Auto” or “Underwater.”
  - For best results, use manual  Custom White Balance and reset for each working depth.
  - Set Drive Mode to “Single Shot .
  - Set Metering to “Center Weighted Avg. .
  - Set ND Filter to “Off.”



## STEP 2 - Initial Camera Settings - continued

Set Image Type to “JPEG 13M” and Image Compression to “L.”

Set Image Quality to “Superfine” and Movies to “FHD/30P.”

- Set ISO to “200.”
- Activate Macro mode  when shooting close-up subjects. If the image is overexposed, use “-” Flash Exposure Compensation   and/or back away, zoom in, and then reshoot.
- RAISE the camera flash **before** placing camera in housing when using only the built-in flash, fiber optic and slave strobes. DO NOT attach the housing Hotshoe Connector. Set Flash to “On-Flash always fires .
- When using external strobes connected to the External Strobe Connector, DO NOT raise the camera flash. Instead, attach the housing hotshoe - **Diagram A, Page 10.**

**Notes:** Manual power settings can be selected in the “Flash Control” section of the camera menu.

\*\* All camera user settings not mentioned should be set to the user's preference.

## STEP 3 - Opening the Housing

Lid Snaps have a **Lock**.

1. Push Lid Snap Locks forward and lift as shown. Open opposing Lid Snaps simultaneously. Keep pressure on the Lid Snaps so they do not fly open quickly.

*Some Lid Snaps have a lot of spring tension once they go over center, so keep a firm grip on each Lid Snap. Lid Snaps may also be opened one at a time.*

2. Remove the Housing Back.

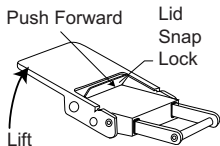

## STEP 4 - Attach Hotshoe to Camera

1. The Mounting Tray for the camera is secured to the housing back.  
Position the camera on the Mounting Tray.
2. **ATTACH** the hotshoe when:
  - NOT using the built-in camera flash.
  - Connecting a strobe(s) to the External Strobe Connector (#1, Page 8).Slide the housing Hotshoe Connector forward into the Camera Hotshoe Mount until it stops, **Diagram A, Page 10**. This should be done **before** the camera is secured with the mounting bolt, **Diagram B, Page 11**, otherwise leave the hotshoe **disconnected** from the camera.  
You will also need to install the Flash Deflector, **Page 17**.

**DO NOT** attach the hotshoe when:

- USING the built-in camera flash.
- Connecting a strobe(s) to the fiber optic ports.

You will also need to install the Flash Diffuser, **Page 17**.

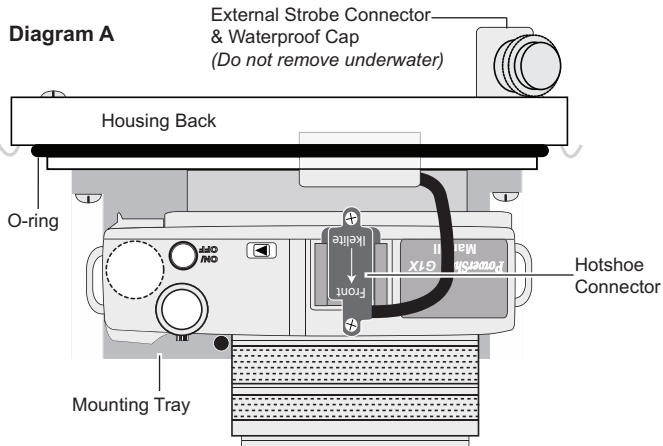

## STEP 5 - Attach Camera to Mounting Tray

- Using a coin or screwdriver (preferred), secure the camera with the Tray Mounting Bolt which threads into the camera's tripod socket, **Diagram B, Page 11**.

### **⚠ CAUTION:**

*Do not cross thread or overtighten the Tray Mounting Bolt as you may damage the camera tripod socket threads.*

**Diagram B**

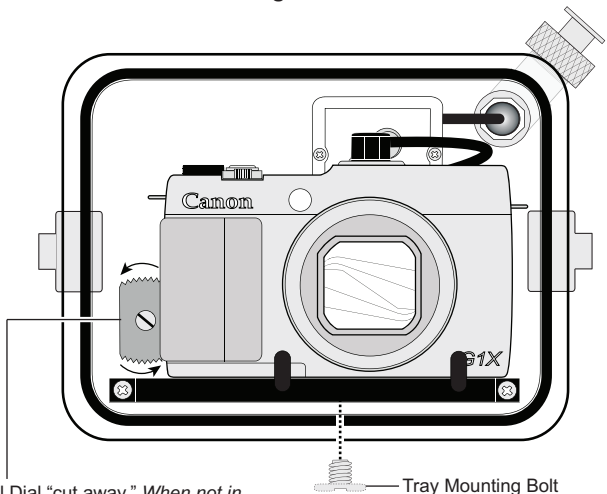

\* Control Dial "cut away." When not in use, rotate Control Dial white dot to the 6 o'clock position so "cut away" is over camera dial and not contacting camera.

## STEP 6 - Attach the Step Ring Gear

The supplied Step Ring Gear is attached to the camera control ring by 3 small nylon Allen Set Screws. Place the Control Ring Gear over the camera's step ring before installing the camera in the housing. The gear is a "press fit" over the lens. Gently tighten all three allen screws with the supplied Allen Wrench as show in the Diagram below. **DO NOT** overtighten or you may damage the gear, or cause it to warp and bow out from the lens Step Ring. Make sure to test it's function once installed.

When installing the camera in the housing, make sure that the Step Ring Gear meshes properly with the smaller black housing gear.

When removing the Gear, leave the Set Screws in the Gear. The Set Screws are very small and easy to lose. Extra Set Screws are included with your housing. We recommend that you leave the gear installed as it makes rotating the camera control ring easier when out of the housing.

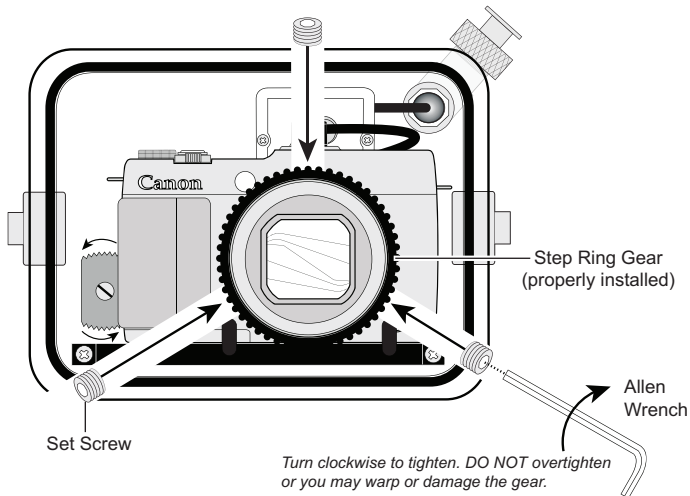

## STEP 7 - Installing Camera in the Housing

1. Pull out on each housing control until it stops. This will get the controls out of the way for installation of the camera. Make sure the Movie Button knob is pulled out and the control is facing toward the bottom of the housing.
2. Remove camera lanyard from camera if attached.
3. Place the Housing Front face down in your lap.
4. Gently guide the Housing Back with camera attached into the Housing Front at a slight angle so the Step Ring Gear and Housing Gear engage properly. Visually check to see that the Gears are properly engaged.

## STEP 8 - Closing the Housing

1. Once the back is properly installed, the o-ring should touch the housing all the way around. There should be an even gap on each side of the housing between the housing and the back.
2. Lift the lid snaps so they are extended and place each lid snap into the corresponding hook on the housing back.
3. To close the housing, push down on the opposing lid snaps simultaneously until they snap into place. Be sure they are down far enough to engage the **Lid Snap Lock**. The o-ring seal should now appear as a solid black line from the back of the housing.

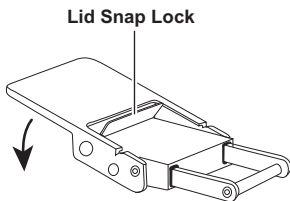
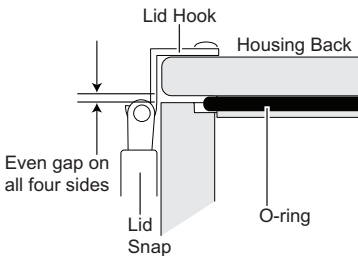

## STEP 9 - Final Check

The clear housing permits instant visual inspection of the camera and sealing surfaces as well as complete monitoring of controls and camera LCD screens. This housing has been factory water pressure tested to 200 ft (60 m).

Once the housing is closed, recheck the o-ring seal. Double check the gap between the housing back and the housing. It should be even all the way around the housing.

Look through the clear plastic back at the o-ring. You should see a darkened area or solid black line where the o-ring is compressed against the housing back. If you do not see an even black compression seal all the way around the back, open the lid snaps, reseal the housing back and close the lid snaps. Visually check the seal again.

### Usage

Turn the camera on and operate each of the housing controls to assure proper functioning. Take a few test shots on land. Make sure the Flash Diffuser is installed when using only the built-in camera flash, or install the Flash Deflector when using external strobes, **Page 17**.

### Strobe Use and Compatibility

*Always install the Flash Deflector when using external strobes.*

### Strobe Compatibility

- AF35.....no
- DS50.....yes, above serial number 70,000
- DS51.....yes
- DS125.....yes, above serial number 5000
- DS160, DS161 .....yes
- DS200.....yes
- Non-Ikelite .....yes, manual flash exposure only

## Ikelite Housing Conversion Circuitry

This small compact housing has Ikelite designed Conversion Circuitry built right in. The Conversion Circuitry provides real Canon eTTL flash exposure when used with Ikelite DS series strobes. Once a DS series strobe is attached to the External Strobe Connector, the conversion circuitry is automatically powered after the strobe is turned on. Once attached, turn the strobe on first before turning on the camera. The circuitry cannot be powered up or used by non-Ikelite strobes.

## Attaching a Sync Cord to the Housing - Diagram C, Page 15

The Housing Bulkhead Connector is designed to accept sync cords with Ikelite ICS-5 connector fittings.

1. Lightly lubricate the Sync Cord O-ring. Use ONLY Ikelite lubricant (supplied with housing).
  2. Remove Bulkhead Cap from Housing Bulkhead.
  3. Line up the Sync Cord Pins with the corresponding Bulkhead Receptacles. Gently insert Sync Cord into Bulkhead. **DO NOT** force this installation. *If the Sync Cord does not seat properly inside the Bulkhead, then the Pins and Receptacles are improperly aligned (repeat Step 3).*
  4. Tighten the Knurled Nut snugly using your Index finger and thumb. **DO NOT** use pliers or other tools to tighten the Knurled Nut.
- Always remove the Sync Cord from your Housing when not in use and replace the Bulkhead Cap.

## Attaching a Sync Cord to the Housing - Diagram C

Diagram C

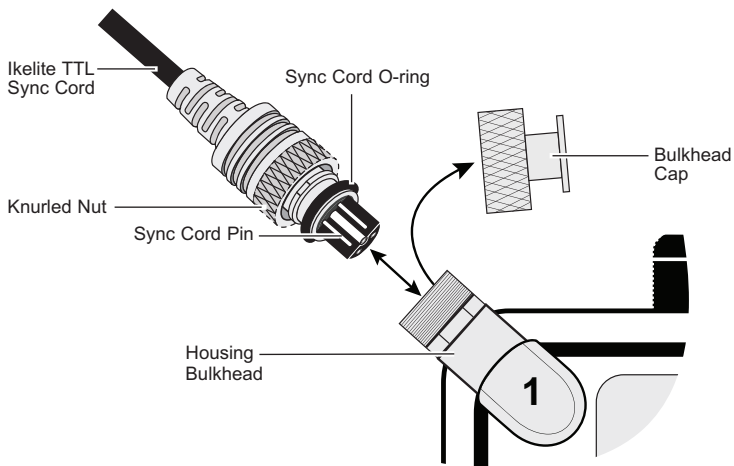

## Using Strobes with a Fiber Optic Connection

Two ports on the front of the housing above the lens port are provided for the connection of up to two Ikelite, SEA&SEA, or Olympus-type fiber optic cords. The housing's built-in TTL circuitry will not be operable when external strobes are attached via fiber optic cord.

*Always install the Flash Deflector when using external strobes, **Page 17**.*



## Diffuser and Deflector Installation

A Diffuser and Deflector are included with the housing. The Diffuser is white transparent plastic. The Deflector is also white but is not transparent.

To install the Diffuser or Deflector, push the “Cut-out” Section over the port and into the port groove until it stops.

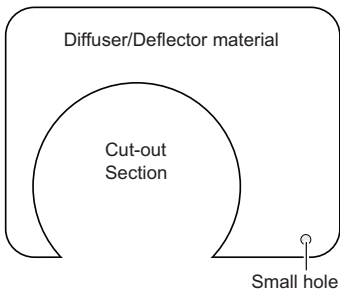

Note the Small Hole. To avoid losing the Diffuser or Deflector, you can attach a fishing line or string to this hole.

Diffuser/Deflector properly installed in port groove

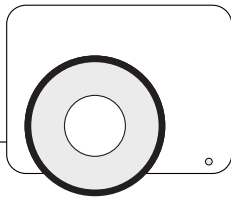

### Diffuser Use

The Diffuser should be installed when using the built-in camera flash only. When shooting close-up photographs with the built-in flash and at the camera lens's widest angle setting, the lens port on the housing can block a portion of the light from the camera flash. This can result in a shadow in a lower corner of the frame. Zoom the lens to eliminate any shadow not eliminated by the Diffuser (*You can test this above water*).

### Deflector Use

The Deflector should be installed whenever an external strobe is being used. This will aid in eliminating backscatter. The Deflector will also block and redirect the camera's flash to a slave unit being used to trigger an external strobe. Remove the Diffuser before attempting to install the Deflector.

## Attaching an Ikelite Strobe Arm to the Housing Handle

To attach an Ikelite Arm to your Housing Handle, depress the spring-loaded Handle Push Button until it stops. Gently slide the pronged end of the Ikelite Arm into the hole in the top of the Handle as shown, **Diagram D**.

When the Ikelite Arm is properly seated, the Handle Push Button will return to its starting position.

**Diagram D**

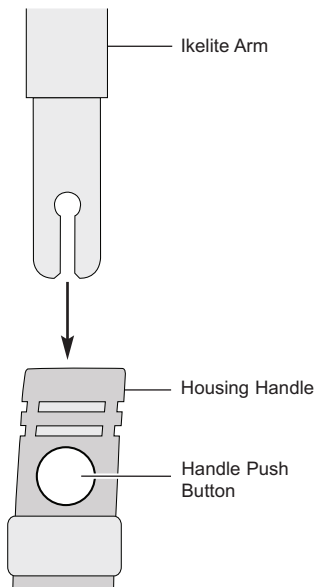

## Entering the Water

As soon as you enter the water, take a moment and check to see that the housing is properly sealed. We recommend you first water test the housing with no camera inside to assure a safe and watertight environment.

Next, check to see if there are any bubbles on the face of the lens port. If there are, take your finger and remove them. If there are bubbles on the lens port they can produce soft focus spots in your photos or video.

## Recommended Accessories

### External Color Correcting UR/Pro Filters (Blue Water or Green Water)

Color filters such as the UR-Pro Filter replace some of the reds, oranges and more natural tones that would otherwise be lost underwater. Effective in relatively shallow, sunny conditions, and available for tropical blue water and green water settings. For optimum results use in combination with custom (manual) white balance.

For available light use only. Not recommended when using external strobes.

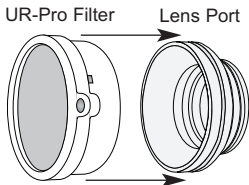

### WD-4 Wide-Angle Conversion Dome 6430.4

The removeable WD-4 corrects light refraction underwater, restoring the camera's original angle of coverage. Approximately 3/4 of the camera's zoom range from the camera's widest angle setting can be used with the dome in place. Slight vignetting may occur at camera's widest angle setting.



## Recommended Accessories - continued

### External Macro Adaptor 9306.82



Allows attachment of 67mm threaded macro lenses from Inon and Epoque. NOT for use with 67mm threaded wide-angle lenses.

**Note:** Other than the 6430.4 and 9306.82, no other accessory lenses or adaptors can be used with this housing.

### Tray + Dual Handles 9523.62

Add stability and gripping point(s) for comfortable use of the housing. Add a second strobe to eliminate shadows and evenly light your subjects.

### External Strobes

An external strobe restores the warmer colors filtered out by water and also illuminates the subject. The camera's flash is not accessible through the housing, therefore, an external strobe is recommended.

### Video Lighting

External video lights such as the 2101 Vega Video + Photo Light add color when using the video/movie mode of your camera. Primary video lights are specially color balanced to provide natural tones.

### Additional Accessories

- 2602.3 Quick Release Handle Kit for GoPro
- Gamma LED Flashlight

\*\* The optional Canon Grip GR-DC1A cannot be used in this installation. Camera must be used with standard grip for proper operation.

A full range of accessories are available to support your housing. Please visit [ikelite.com](http://ikelite.com) to see the most current information about recommended accessories for your housing.

## Maintenance

### Lens Port

Treat the glass in the lens port as a camera lens. After use, rinse and gently dry the outside lens port to avoid water spotting. To clean, use a mild soap solution or lens cleaner. It is NOT necessary to remove the Port for cleaning. Do not rinse the inside the Port.

**Do not use alcohol or window cleaner on the Lens Port.**

### Lubricant

Ikelite provides silicone lubricant with the housing. We recommend you use **only** Ikelite lubricant on Ikelite products. Other brands may cause the main housing o-ring to swell and not seal properly.

Use only enough lubricant to lightly cover the main housing o-ring or lubricate a sticky control. Wipe off any excess lubricant with a clean cloth. Lubricant is not a sealant; it is used to reduce friction. Excessive lubricant can collect sand and dirt which may interfere with proper sealing.

#### **CAUTION:**

**Never use spray lubricants as the propellant ingredient can cause the plastic housing to crack or o-rings to swell.**

## Housing Maintenance

Your Ikelite Digital Housing should be given the same care and attention as your other photographic equipment. In addition to normal maintenance, we recommend that the housing be returned to Ikelite periodically to be checked and pressure tested.

- **Do Not** leave the camera and housing in direct sunlight for prolonged periods. Heat may damage the camera.
- **Do Not** ship the camera in the housing.
- Before using the housing, always check the tightness of the **set screw** in each control knob. Check each **control gland** penetrating the housing to make sure they are tight. There is a slight chance that either could vibrate loose during travel.
- Keep the main housing o-ring clean and lightly lubricated. To lubricate, remove the o-ring from the back. Put a small amount of Ikelite lubricant on your fingers. Pull the o-ring through your fingers to apply a **thin** coating of lubricant. Only apply enough lubricant to make the o-ring feel slick. **Do Not stretch the o-ring**. This light coating of lubricant will help to keep the o-ring from drying out and will help to show a dark sealing line when the housing back is properly sealed.
- Keep the area where the o-ring fits and the sealing surface of the housing clean.
- Rinse the housing exterior thoroughly in freshwater after each saltwater use. Depress push buttons repeatedly in freshwater to eliminate trapped saltwater. Dry with a soft cloth. Dry lens port to eliminate water spotting. After several uses in saltwater, soak the housing exterior in a mild soap solution; rinse and dry before storing. When storing the housing, remove the back o-ring, lightly lubricate, and place in a plastic bag. Place the plastic bag with o-ring inside the housing for safe keeping.
- If removing a housing push button, **Do Not** re-use the E-clip. Contact Ikelite for replacement E-clips (part 0319.12).
- Leave lid snaps in the open position when not using the housing for extended periods.

## Control Maintenance

*Ikelite controls are designed to provide years of reliable service with minimal maintenance.*

- Push button controls normally require no maintenance other than rinsing in freshwater after saltwater use. Depress each push button in freshwater several times to eliminate trapped saltwater. If a push button control becomes difficult to push or if it sticks when depressed, soak the housing in luke warm freshwater. After a few minutes, operate the push button. If this does not correct the problem, return the housing to Ikelite for maintenance. If you are on a trip and unable to return the housing immediately, a push button may be lubricated by pressing and holding the push button all the way in. Then, use your finger or other small non-metal object to place a small amount of lube at the base of the shaft inside the housing. Press and release the push button several times until the lube is worked up into the o-ring.

After completing this procedure, close the housing and submerge it in water without the camera inside. Check the control for watertightness.

**Diagram E**

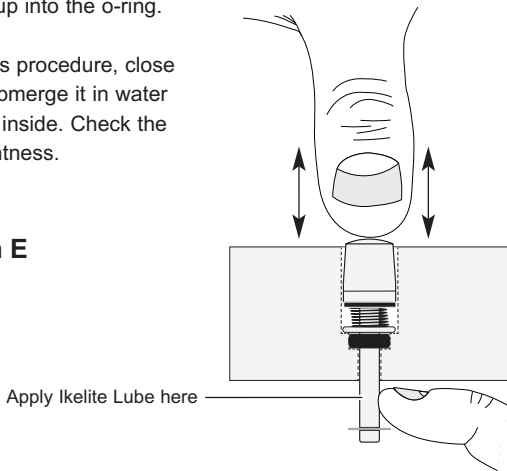

## Control Maintenance - continued

In the unlikely event one of the larger gland style control shafts sticks or becomes difficult to operate, you can remove the control from the housing and lubricate it, or return the housing to Ikelite for maintenance.

To remove the control, **Diagram F**, loosen the set screw in the knob (allen wrench required); remove the knob. If there is salt or dirt build-up on the exposed control shaft, clean the shaft. Open the housing and gently slide the control shaft out of the control gland. Clean and lightly lubricate the shaft, including the end of the shaft.

Slide the shaft back into the control gland and gently slide it back and forth a few times without fully removing the shaft from the gland.

Replace the knob, noting the flat area on the shaft. The set screw in the knob should tighten down against the flat area on the control so the knob does not turn on the shaft.

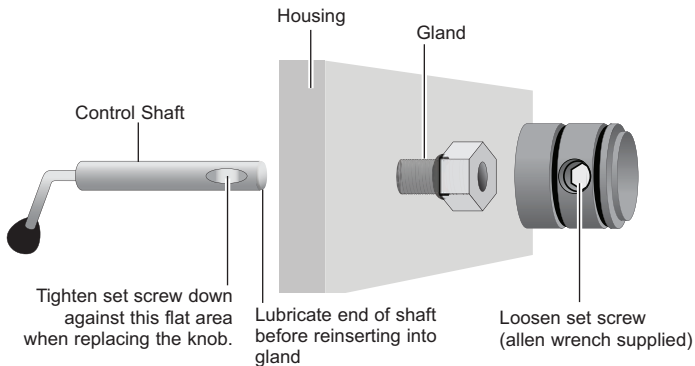

After completing this procedure, close the housing and submerge it in water without the camera inside. Check the control for watertightness.

**Diagram F**







## Photo Tips

- The number one rule in underwater photography is to eliminate as much water between the camera and subject as possible. Get as close as you can to the subject, then use the zoom. If you are using flash for still photos, subjects beyond 6 ft (1.8 m) will not have much color regardless of strobe power.
- Photograph in clear water; do not stir up the sand or silty bottom. If backscatter becomes a problem in the environment you are photographing, an external flash will help eliminate much of the backscatter.
- Many digital cameras have a slight lag time between when you press the shutter release button and the camera actually takes the picture. Hold the housing steady a second or two after pressing the shutter release button.
- Do not shoot down on subjects as they will quite often blend into the background and be difficult to see in the photograph. Shoot subjects straight on or shoot up at a slight angle using the blue water as a contrasting background.
- When using daylight or flash, if your camera consistently over or underexposes the image, you may want to adjust your camera's exposure compensation  or flash exp. comp.  settings.
- If you error in exposure, it is better to have the image slightly underexposed rather than overexposed. An overexposed image is missing color information which cannot be adjusted in a photo processing program. A slightly underexposed image has color information that can be adjusted.
- It is important to respect all living creatures underwater, including people, marine life, and coral. While we encourage people to get close to their subjects when taking a photograph, they should not touch, lie on, or in any way disturb the things they find underwater.

## Troubleshooting

Problem	Solution
Push buttons or controls are sticky or hard to operate	<ul style="list-style-type: none"><li>- Remove the camera and rinse the closed housing in freshwater. Vigorously press each push button in and out several times to release any trapped saltwater or debris.</li><li>- Press a sticky push button all the way in and place a small amount of lube on the small end of the push button shaft at it's base. Release and operate the push button several times to distribute the lube, <b>Diagram E, Page 23</b>.</li><li>- If a larger gland style control is sticky, grab the control knob, pull it out, and then push back in. If still sticky, see the Control Maintenance section, <b>Diagram F, Page 24</b>.</li><li>- Return housing to Ikelite for routine maintenance.</li></ul>
Image is over/underexposed, or a corner of the image is dark	<ul style="list-style-type: none"><li>- Check that the built-in flash or external strobe is firing when taking a picture. Camera flash should be forced "on."</li><li>- When using an external strobe, make sure it is turned on, set properly, and its battery is charged.</li><li>- Make sure the diffuser is installed when you are NOT using an external strobe.</li><li>- Check any corded connection points.</li><li>- Change camera shutter speed or aperture.</li><li>- Move closer to or further away from the subject.</li><li>- Adjust Flash Exposure Compensation  .</li><li>- For extreme overexposure turn on the ND neutral density filter.</li></ul>

Problem	Solution
Camera does not take a picture	<ul style="list-style-type: none"> <li>- Install a fully charged battery.</li> <li>- There is not enough available light for the camera to properly focus. Add a focusing light or strobe with a built-in focusing or video light to your system.</li> <li>- Select a center focus point in your camera menu.</li> <li>- Return Zoom control to the “disengaged” position, see Zoom Control, <b>Page 28</b>.</li> </ul>
Housing is hard to close	<ul style="list-style-type: none"> <li>- Make sure the camera is mounted properly in the housing and controls are out of the way.</li> <li>- Main housing o-ring is not seated properly.</li> <li>- Hotshoe cord is in the way.</li> <li>- Step Ring is not engaging housing gear properly.</li> </ul>
Fogging occurs on the Lens Port	<ul style="list-style-type: none"> <li>- Humid air is trapped inside the housing. The camera produces heat and may condense any trapped moisture forming fog on the lens port. Close the housing in an air-conditioned room or vehicle, or in front of an air-conditioner.</li> <li>- The housing should not be in direct sunlight for an extended period of time.</li> <li>- Purchase desiccant packs also known as moisture munchers from a local camera store. Place one or two new packs in your housing before each day of diving.</li> <li>- If moisture or water droplets are present around the controls or sealing areas, return the housing to Ikelite for evaluation.</li> <li>- Clean the main housing o-ring and sealing surface of the housing.</li> </ul>

Problem	Solution
Water enters the housing	<ul style="list-style-type: none"> <li>- Remove, clean and properly lubricate the main o-ring.</li> <li>- Look for hair, dirt, or foreign debris crossing the o-ring seal.</li> <li>- Reassemble the housing without a camera installed and immerse in water.</li> <li>- Return housing to Ikelite for evaluation.</li> </ul>
Pictures are too blue or too green	<ul style="list-style-type: none"> <li>- Use custom (manual) white balance. Reset for each working depth or when attaching a color correcting filter to the camera lens.</li> <li>- Add an external strobe.</li> <li>- Move in closer to your subject when taking a picture.</li> <li>- Add an optional color correcting filter to the Housing Port.</li> </ul>

## Zoom Control

After you have used the housing's zoom control, it must be returned to the center position to disengage. If the housing zoom control is pushing the zoom lever in either direction, you may not be able to take a picture or access other functions. This is because the camera is receiving a signal from the engaged zoom control.



Zoom Control  
"Disengaged"  
(Center Position)



Zoom Control  
"Engaged"

## **Spare Parts** (available through Ikelite or any Ikelite Dealer)

- 9104.5 Waterproof Bulkhead Cap
- 0184.2 Silicone Lubricant 2cc  
Reclosable Tube
- 0132.30 Port o-ring
- 0200.08 Port cover
- 0110 Main o-ring
- 0945.18 allen wrench for control knobs
- 0945.11 allen wrench for Step Ring small nylon set screws
- 9299.07 KIT contains 6 Step Ring small nylon set screws and allen wrench

## Customer Support

Please read the troubleshooting section of this instruction manual before contacting Ikelite Customer Support.

**Ikelite Underwater Systems  
Service Department  
50 West 33rd St.  
Indianapolis, IN 46208 USA**

Email: [ikelite@ikelite.com](mailto:ikelite@ikelite.com)

Phone: 317-923-4523

## Limited Warranty

This Ikelite product is warranted against any manufacturing defects for a period of one (1) year from the original date of purchase. Defective products should be returned to Ikelite postage paid. Ikelite will, at its sole discretion, repair or replace such products, and will return to customer postage paid. All other claims of any nature are not covered. Except as mentioned above, no other warranty expressed or implied applies to this Ikelite product.

## Returning Products For Service

Ikelite is most interested in performing any service to ensure that all products perform as intended. Evidence of purchase date must be provided to obtain warranty service.

No prior authorization is required. You may return directly to us or through your dealer. Please include a brief description of the problem, any relevant email correspondence, and/or instructions on what you want us to do. Always include name, shipping address, email address, and phone number inside of the package. Send postage paid to:

**Ikelite Underwater Systems**

**Attention: Service Department**

**50 West 33 Street**

**Indianapolis, IN 46208 USA**

*No reimbursements for postage paid will be issued.*

*You may also want to insure the package.*

## Returning Products for Service - outside the United States

For the separate international customs documentation form that you complete to accompany the shipment, please state or designate that the enclosed products were originally manufactured in the USA and are being returned to the manufacturer for repair service. Value of the equipment listed for customs purposes should be zero.

## Product Registration

Please go to **ikelite.com** to register your Ikelite housing within 15 days of purchase.



**Ikelite Underwater Systems  
50 West 33rd Street  
Indianapolis, IN 46208 USA**

**ikelite.com**

© 2015 Ikelite Underwater Systems

6146.02\_Canon\_G1X\_MarkII\_04-0718