



Underwater Housing for Sony RX100 III, RX100 IV, RX100 V

Product Number 6116.14

I n s t r u c t i o n M a n u a l

Thank you for your purchase of Ikelite equipment. Please read this instruction manual completely before attempting to operate or dive with this product. Please refer to the back page of this manual to register your Ikelite product.

Table of Contents

Preparation	P. 3
Specifications	P. 4
What's in the Box	P. 4
Parts of the Housing - Front View	P. 5
Parts of the Housing - Back View	P. 6
Housing and Camera Setup	P. 7
STEP 1 - Initial Camera Setup	P. 7, 8
STEP 2 - Opening the Housing	P. 8
STEP 3 - Camera Installation/Removal	P. 8 - 10
STEP 4 - Closing the Housing	P. 10
STEP 5 - Final Check	P. 11
Housing Usage	P. 11
Zoom Control Use	P. 12
Built-in Flash and Strobe Use	P. 12
Strobe Use	P. 12
Using the Camera's Built-in Flash	P. 13
Deflector Installation and Removal	P. 13
Diffuser Purpose	P. 14
Diffuser Installation and Removal	P. 14
Entering the Water	P. 15
Recommended Accessories and Attachments	P. 15 - 18
Maintenance	P. 19 - 24

Table of Contents - continued

Photo Tips	P. 25
Troubleshooting	P. 26 - 28
Spare Parts	P. 29
Customer Support	P. 29
Limited Warranty	P. 30
Returning Products for Service	P. 31
Product Registration	Back Page

Preparation

This product has been water pressure tested at the factory and is depth rated to 200 ft (60 m). Thoroughly inspect and immerse the empty housing completely in water before installing a camera. If any fogging occurs or droplets of water enter the housing, do not install a camera. Clean the main housing o-ring and retest to make sure that it is watertight. Refer to the Troubleshooting section, **page 26**.

Please read your camera manual thoroughly to have a full understanding of each camera function.

If you are new to underwater photography, be sure to read the Photo Tips section, **page 25**.

Specifications (no camera installed)

Depth Rating200 ft (60 m)
ControlsAll camera functions accessed exceptviewfinder and flash pop-up switches
BuoyancySlightly negative in fresh water
Housing Weight2.6 lb (1180 g)
Strobe ConnectionFiber Optic Ports
Use Built-in FlashYes (flash diffuser included)
Optional Tray Mounting1/4-20 thread external tray mounting with3-inch (76 mm) spacing
Main O-Ring0109
Housing DimensionsDimensions 6.8 x 5.0 x 5.4 in (173 x 127 x137 mm)
Housing MaterialPolycarbonate front, acrylic back
Lens Port3-inch diameter glass

What's in the Box

- Housing (with lanyard attached)
- Port Cover
- Flash Diffuser
- Flash Deflector (removeable from housing)
- Silicone 1cc Lubricant Tube

Parts of the Housing - Front View



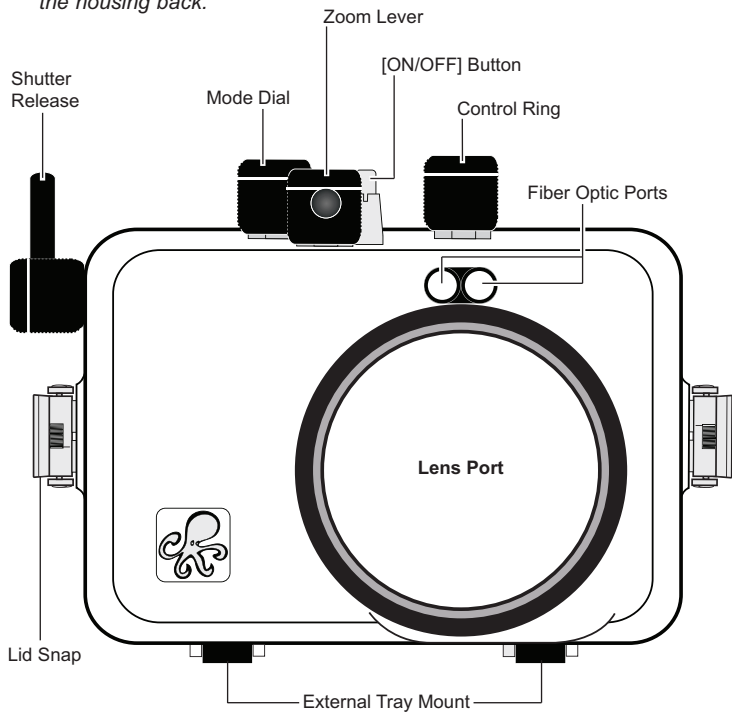



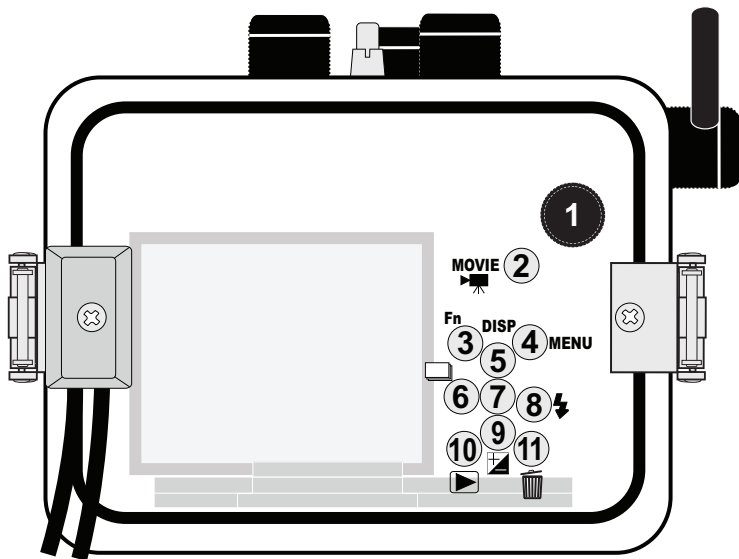

Housing controls are provided for all camera functions except for the viewfinder and flash pop-up switches. The built-in camera flash must be extended AFTER placing the camera in the housing, but before attaching the housing back.



Control Ring: To properly engage the Control Ring on the surface or in shallow water, apply slight downward pressure as you rotate the knob.

Parts of the Housing - Back View







1. Control Wheel
2.  Movie Button
3. **Fn** Function Button
4. **MENU** Button
5.  Up Cursor / **DISP**
6.  Left Cursor / Multi-shot
7.  MENU/SET Button
8.  Right Cursor / Flash Setting
9.  Down Cursor / Exp. Comp.
10.  Playback Button
11.  Delete / Custom Button

Housing and Camera Setup

STEP 1 - Initial Camera Setup (before placing camera in housing)

Setup your camera for underwater use and then adjust your settings once underwater.



- Set Mode Dial to “A” Aperture Priority. Manually adjust aperture setting to achieve the best exposure for your shooting conditions. The shutter speed will be locked at 1/30th second. If a faster shutter speed is desired, set Mode Dial to “M” Manual mode to manually adjust both aperture and shutter speed settings.
- In  **MENU settings:**
 - Set Image Size to “L: 18M” and Img. Size(Dual Rec) to “L: 17M.”
 - Set aspect Ratio to “4:3” or other preferred setting.
 - Set Quality and Quality(Dual Rec) to “X.FINE” Extra Fine.”
 - Set Drive Mode to “Single Shooting” and Flash Mode to  “Fill Flash.”
 - Set Red Eye Reduction to “Off.”
 - Set Focus Mode to “Single-shot AF” and Focus Area to “Center.”
 - Set AF Illuminator to “Off”, ISO to “200” and ND Filter to “Off.”
 - Set Metering Mode to “Center” and White Balance to “Auto AWB.”
 - Always use auto white balance (AWB) when using a strobe/flash. When recording video, AWB can still be used, but for more accurate and consistent colors we recommend setting Custom manual white balance  for each working depth. Custom manual white balance is also recommended when using a color filter and no flash.
 - Set DRO/Auto HDR, Center Lock-on AF & Smile/Face Detect to “OFF.”
 - Set SteadyShot to “On” and “Active.”
- In **CUSTOM MENU settings**, set Auto Review to “5 Sec.”
- In  **SETUP MENU settings:**
 - Set Pre-AF to “On” and Zoom Setting to “Optical Zoom Only.”
 - Set Monitor Brightness to “Manual +1.”
 - Set Pwr Save Start Time to “5 min.”

STEP 1 - Initial Camera Setup - continued

Set Function for VF Close to "Not Power Off."

Set Date/Time Setup.

Insert and Format a memory card.

- If close-up images are **overexposed**, adjust aperture setting and/or use "-"   Flash Exposure Compensation and/or back away, zoom in, and then reshoot. When using an AF35 strobe or manual controller, turn the power down.

** All camera user settings not listed should be set to the user's preference.

STEP 2 - Opening the Housing

Lid Snaps have a **Lock**.

1. Push Lid Snap Locks forward and lift as shown. Open opposing Lid Snaps simultaneously. Keep pressure on the Lid Snaps so they do not fly open quickly.

Some Lid Snaps have a lot of spring tension once they go over center, so keep a firm grip on each Lid Snap. Lid Snaps may also be opened one at a time.

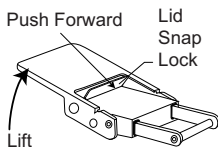

2. Remove the Housing Back.

STEP 3 - Camera Installation/Removal

RX100 III IMPORTANT NOTE: *If using the Sony RX100 III model camera, add the small 1/16" thick rubber washer (included in box) to the rear housing dial. Remove the adhesive backing on the washer before application.*

1. Pull out on each housing top control until it stops. This will get the controls out of the way for installation of the camera.
2. Remove camera lanyard from camera if attached.
3. Slide the Mounting Tray out of the camera Mounting Plate. Use the index and middle fingers of each hand to pull the Tab section of the Mounting Tray away from the Mounting Plate, **Diagram A, page 9.**

STEP 3 - Camera Installation/Removal - continued

Diagram A

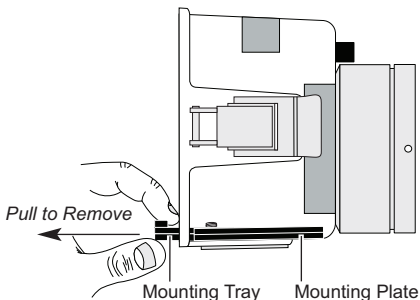
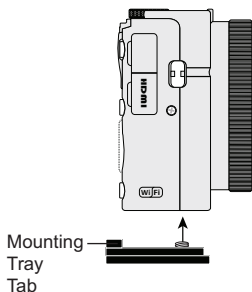

Diagram B



- Using a coin or flathead screwdriver (preferred), secure the camera Mounting Tray to the camera tripod mount, **Diagram B**. The Mounting Tray only attaches one way with the Tab to the back of the camera. An additional Tray hole allows attachment to a land tripod stand.

⚠ CAUTION:

Do not cross thread or overtighten the Mounting Tray Bolt as you may damage the camera tripod socket threads.

- Gently slide the camera with Mounting Tray back into the Mounting Plate, **Diagram C, page 10**. Using your thumb, push against the Mounting Tray Tab until the Tray stops sliding forward into the Mounting Plate. Give the Tray an extra push to make sure it is properly seated all the way forward into the Mounting Plate.
- Slide Flash Pop-up Switch to extend camera Flash. **NOTE:** Once the housing is closed you cannot extend the camera Flash.
- Close the Housing, **Step 4, page 10**.

** To REMOVE camera from housing, reverse procedure, Diagram A.

STEP 3 - Camera Installation/Removal - continued

Diagram C

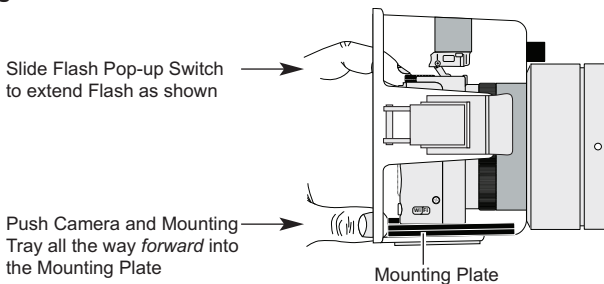

STEP 4 - Closing the Housing

1. Once the back is properly installed, the o-ring should touch the housing all the way around. There should be an even gap on each side of the housing between the housing and the back.
2. Lift the lid snaps so they are extended and place each lid snap into the corresponding hook on the housing back.
3. To close the housing, push down on the opposing lid snaps simultaneously until they snap into place. Be sure they are down far enough to engage the **Lid Snap Lock**. The o-ring seal should now appear as a solid black line from the back of the housing.

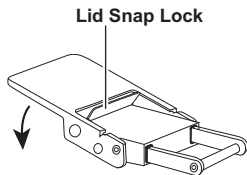
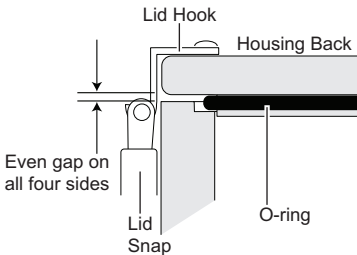

STEP 5 - Final Check

The clear housing permits instant visual inspection of the camera and sealing surfaces as well as complete monitoring of controls and camera LCD screens. This housing has been factory water pressure tested to 200 ft (60 m).

Once the housing is closed, recheck the o-ring seal. Double check the gap between the housing back and the housing. It should be even all the way around the housing.

Look through the clear plastic back at the o-ring. You should see a darkened area or solid black line where the o-ring is compressed against the housing back. If you do not see an even black compression seal all the way around the back, open the lid snaps, reseal the housing back and close the lid snaps. Visually check the seal again.

Housing Usage

Turn the camera on and operate each of the housing controls to assure proper functioning. Take a few test shots on land. Make sure the Flash Diffuser is installed when using only the built-in camera flash, or install the Flash Deflector when using external strobes, **Pages 13 and 14**.

Zoom Control Use

After you have used the housing's zoom control, it must be returned to the center position to disengage. If the housing zoom control is pushing the zoom lever in either direction, you may not be able to take a picture or access other functions. This is because the camera is receiving a signal from the engaged zoom control.



Zoom Control
"Disengaged"
(Center Position)



Zoom Control
"Engaged"

Built-in Flash and Strobe Use

*Always install the Flash **Deflector** when using external strobes, **Page 13**. Always remove the **Deflector** and install the Flash **Diffuser** when using only the built-in flash, **Pages 13 and 14**.*

Strobe Use

The optional AF35 strobe triggers and provides automatic TTL exposure by watching the camera's built-in flash, without the need of fiber optic cords or sensors. Alternatively, two ports are provided on the front of the housing for the connection of up to two Ikelite, SEA&SEA, or Olympus type fiber optic cords.

An included flash diffuser improves lighting quality when the camera's built-in flash is used. The built-in flash is effective between 1-3 feet (0.3-0.9 m) from the subject in clear conditions. For best results, a color correcting filter or external lighting is recommended. External lighting is more powerful and can be placed in a position to virtually eliminate the backscatter or "snow" from your underwater images.

*Always install the Flash Deflector when using external strobes, **Page 13**.*

Using the Camera's Built-in Flash

If you are shooting with the camera's built-in flash and the camera lens is set to the widest angle setting, you may need to zoom the lens slightly or a dark area may appear in a lower corner of close-up photographs. The lens port may block some of the light. Install the Diffuser, **page 14**, and zoom in to eliminate any dark areas noted in your photographs (*You can test this above water*).

For the best results, we recommend using external Strobes.

The camera's built-in flash CANNOT be used with optional Wide Angle or Accessory lenses, or when the housing Deflector is installed.

Deflector Installation and Removal

The factory installed flash Deflector should be removed and replaced by the Diffuser, **page 14**, when using ONLY the built-in camera flash and no external strobes. To **remove**, lift the bottom of the Deflector with your thumb, or a Pen or Pencil tip to loosen and pull the Deflector away from the inside front of the housing. To **install**, line up the corresponding Velcro dots on the housing front with the **Deflector Back** and press the Deflector into its factory installed position next to the lens port. If positioned properly, the small deflector holes will line up with the Fiber Optic Port holes.

Deflector Front (view from inside housing)

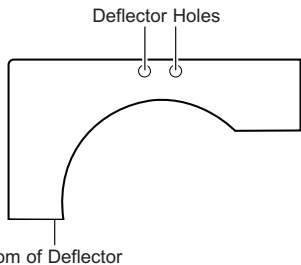

Deflector Back (view from outside housing)

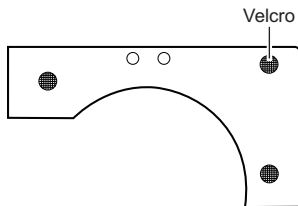

Diffuser Purpose

When using the built-in camera flash and shooting close-up photographs, the lens port on the housing can block a portion of the light from the built-in camera flash. This can result in a shadow in a lower corner of the picture frame. The Diffuser will help eliminate the shadow. In addition, you can zoom in if necessary.

Diffuser Installation and Removal

The included Diffuser should only be used when shooting with the built-in camera flash. Always remove the Deflector **before** using **ONLY** the built-in camera flash with a Diffuser.

To install the diffuser, push the “Cut-out Section” into the Port Groove until it stops as shown. To remove, grab the top of the Diffuser and pull away from the port.

Note the Small Hole. To avoid losing the diffuser, you can attach a fishing line or string to this hole.

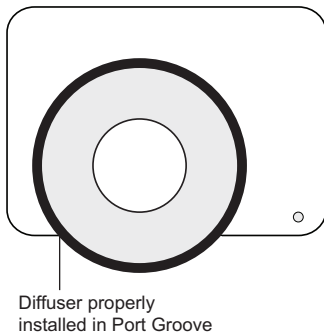
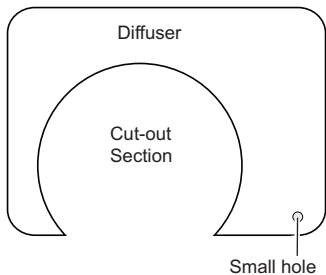

Entering the Water

As soon as you enter the water, take a moment and check to see that the housing is properly sealed. We recommend you first water test the housing with no camera inside to assure a safe and watertight environment.

Next, check to see if there are any bubbles on the face of the lens port. If there are, take your finger and remove them. If there are bubbles on the lens port they can produce soft focus spots in your photos or video.

Recommended Accessories

External Color Correcting Filters

The specially formulated UR/Pro color correcting filter 6441.41 for tropical **blue water** settings enhances warm reds and oranges with available sunlight up to 80 ft (24 m). Use in the Caribbean, Indonesia, and any blue water setting.

The UR/Pro color correcting filter 6441.81 for **green water** enhances contrast and improves the color of green water to give your subject a rich, natural tone. Effective with available sunlight up to 80 ft (24 m). Use in most lakes and any green water setting. The color filters are for available light use only. Not recommended when using external strobes.

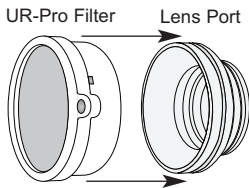

Optional Tray with Release Handle 9523.63

The optional aluminum tray with release handle comes with the necessary hardware to mount to your Ikelite housing. To attach, see **page 16**.



Optional Tray + Dual Handles 9523.64

Attaching an optional Tray + Dual Handles will add stability and gripping point(s) for comfortable use of the housing. Add a second strobe to eliminate shadows and evenly light your subjects.



Attach Optional Tray + Release Handle(s) to Housing

1. Place the housing upside down on a flat surface or in your lap so that the housing port is facing toward you as shown.
2. Line up the 3/8" tray holes with the housing mounts. If the tray is positioned properly, the handle will be on your left side facing down.
3. Place a shoulder washer in each 3/8" tray hole with the small end of the washer facing down.
4. With your free hand, insert and rotate the 1/4-20 screws clockwise until threaded into the housing mounts. Finish tightening the tray to the housing using a flathead screwdriver. Do not overtighten.

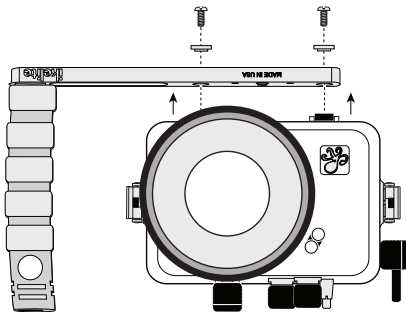

Attach Optional Strobe Arm to Housing Handle

If you have purchased an optional Ikelite Tray and Handle for your housing, an Ikelite Strobe Arm will easily attach to the Handle by depressing the spring-loaded Handle Push Button until it stops. Gently slide the pronged end of the Ikelite Arm into the hole in the top of the Handle as shown.

When the Ikelite Arm is properly seated, the Handle Push Button will return to its starting position.

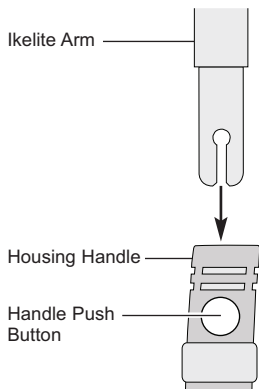

AF35 Strobe Package 4035

The AutoFlash AF35 kit is a great compliment, and an effortless, affordable way to add a flash to your new Ikelite point and shoot camera system. Everything you need to get started is in the box. Just attach it to the bottom of your housing and start taking pictures!

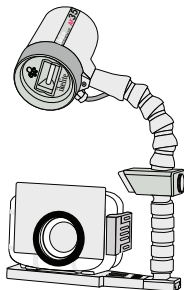

The AF35 Strobe Package is available to support your housing along with a full range of accessories. Please visit ikelite.com to see additional information regarding this and other strobe package options.

External Accessory Lenses

The housing port is designed to accept 3.0-inch diameter color filters, and wide angle or macro options with 67mm threads. Light is absorbed very quickly as it passes through water. A subject will look darker, less colorful and somewhat grainy when viewed through even a few feet of water. The addition of a compatible wide angle accessory expands the camera's field of view underwater, providing the opportunity to get as close as possible to the subject and reduce the amount of water light passes through.

We recommend the Ikelite 6430 W30 Wide Angle Lens or INON UWL-H100 Wide Angle Lens for excellent edge sharpness with minimal vignetting (dark shadows in the corners of the image). Vignetting may be eliminated by either zooming slightly or cropping the image in post-production.

- The camera's built-in flash cannot be used with External Accessory Lenses.
- Bayonet mount lenses cannot be used with this housing.
- Please visit ikelite.com for additional information.

W30 Lens

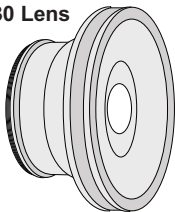

Recommended Accessories - continued

Video Lighting

External video lights such as the 2101 Vega Video + Photo Light add color when using the video/movie mode of your camera. Primary video lights are specially color balanced to provide natural tones.

- 2602.3 Quick Release Handle Kit for GoPro
- Gamma LED Focus/Flashlight

A full range of accessories are available to support your housing. Please visit ikelite.com to see the most current information about recommended accessories for your housing.

Maintenance

Lens Port

Treat the glass in the lens port as a camera lens. After use, rinse and gently dry the outside lens port to avoid water spotting. To clean, use a mild soap solution or lens cleaner. It is NOT necessary to remove the Port for cleaning. Do not rinse the inside the Port.

Do not use alcohol or window cleaner on the Lens Port.

Lubricant

Ikelite provides silicone lubricant with the housing. We recommend you use **only** Ikelite lubricant on Ikelite products. Other brands may cause the main housing o-ring to swell and not seal properly.

Use only enough lubricant to lightly cover the main housing o-ring or lubricate a sticky control. Wipe off any excess lubricant with a clean cloth. Lubricant is not a sealant; it is used to reduce friction. Excessive lubricant can collect sand and dirt which may interfere with proper sealing.

CAUTION:

Never use spray lubricants as the propellant ingredient can cause the plastic housing to crack or o-rings to swell.

O-ring Storage

When storing the housing, remove the main housing o-ring. Lightly lubricate the o-ring until it appears shiny and place in a small resealable plastic bag. Use only Ikelite lubricant. Place the bag inside the housing and store until needed.

Housing Maintenance

Your Ikelite Digital Housing should be given the same care and attention as your other photographic equipment. In addition to normal maintenance, we recommend that the housing be returned to Ikelite periodically to be checked and pressure tested.

- **Do Not** leave the camera and housing in direct sunlight for prolonged periods. Heat may damage the camera.
- **Do Not** ship the camera in the housing.
- Before using the housing, always check the tightness of the **set screw** in each control knob. Check each **control gland** penetrating the housing to make sure they are tight. There is a slight chance that either could vibrate loose during travel.
- Keep the main housing o-ring clean and lightly lubricated. To lubricate, remove the o-ring from the back. Put a small amount of Ikelite lubricant on your fingers. Pull the o-ring through your fingers to apply a **thin** coating of lubricant. Only apply enough lubricant to make the o-ring feel slick. **Do Not stretch the o-ring**. This light coating of lubricant will help to keep the o-ring from drying out and will help to show a dark sealing line when the housing back is properly sealed.
- Keep the area where the o-ring fits and the sealing surface of the housing clean.
- Rinse the housing exterior thoroughly in fresh water after each saltwater use. Depress push buttons repeatedly in fresh water to eliminate trapped saltwater. Dry with a soft cloth. Dry lens port to eliminate water spotting. After several uses in saltwater, soak the housing exterior in a mild soap solution; rinse and dry before storing. When storing the housing, remove the back o-ring, lightly lubricate, and place in a plastic bag. Place the plastic bag with o-ring inside the housing for safe keeping.
- If removing a housing push button, **Do Not** re-use the E-clip. Contact Ikelite for replacement E-clips (part 0319.12).
- Leave lid snaps in the open position when not using the housing for extended periods.

Control Maintenance

Ikelite controls are designed to provide years of reliable service with minimal maintenance.

- Push button controls normally require no maintenance other than rinsing in freshwater after saltwater use. Depress each push button in fresh water several times to eliminate trapped saltwater. If a push button control becomes difficult to push or if it sticks when depressed, soak the housing in luke warm fresh water. After a few minutes, operate the push button. If this does not correct the problem, return the housing to Ikelite for maintenance. If you are on a trip and unable to return the housing immediately, a push button may be lubricated by pressing and holding the push button all the way in. Then, use your finger or other small non-metal object to place a small amount of lube at the base of the shaft inside the housing. Press and release the push button several times until the lube is worked up into the o-ring.

After completing this procedure, close the housing and submerge it in water without the camera inside. Check the control for watertightness.

Diagram E

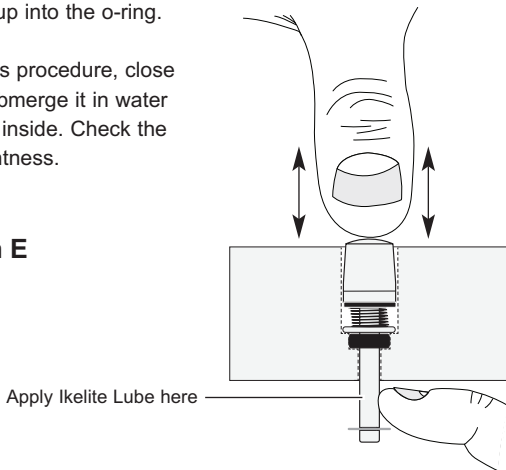

Control Maintenance - continued

Ikelite controls are designed to provide years of reliable service with minimal maintenance.

In the unlikely event one of the control shafts sticks or becomes difficult to operate, you can remove the control from the housing and lubricate it, or return the housing to Ikelite for maintenance.

Your housing features both **round** and **hex** style control glands. To remove a control in a **round** style gland, **Diagram F, page 24**, loosen the set screw in the knob (allen wrench required); remove the knob. If there is salt or dirt build-up on the exposed control shaft, clean the shaft. Open the housing and gently slide the control shaft out of the control gland. Clean and lightly lubricate the shaft and o-rings, including the large end of the shaft.

If there is a shutter spring on the Control Shaft, make sure it is in its proper position. Rotate the Shaft back and forth slightly to aid installation back into the Control Gland. Replace the knob with the Set Screw over the Control Flat. The Set Screw in the knob should be tightened down against the flat area on the Control Shaft so the knob does not turn on the shaft.

Control Maintenance - continued

- Some of the controls have long shafts and feature a **hex** style control gland. These controls can be pulled out, exposing the shaft, **Diagram G, page 24**.

To lubricate the control, gently pull on the knob until the stainless steel shaft is exposed. Lightly lubricate the shaft, then move the shaft in and out several times. This will lubricate the x-ring in the Ikelite control gland. This should be done before using the housing after a prolonged storage period, or once a week when the housing is in constant use.

- Some of the controls have a short shaft and cannot be pulled out exposing the shaft for lubrication. In the unlikely event one of these controls sticks or becomes difficult to operate you can remove the control from the housing and lubricate it, or return the housing to Ikelite for maintenance. To remove the control, **Diagram H, page 24**, loosen the set screw in the knob (allen wrench required); remove the knob. If there is salt or dirt build-up on the exposed control shaft, clean the shaft. Open the housing and gently slide the control shaft out of the control gland. Clean and lightly lubricate the shaft, including the end of the shaft. Slide the shaft back into the control gland and gently slide the shaft back and forth a few times without fully removing the shaft from the gland. Replace the knob noting the flat area on the shaft. The set screw in the knob should tighten down against the flat area on the control, so the knob does not turn on the shaft.

Close housing **without** a camera inside and water pressure test in a bathtub or swimming pool. Rotate* the knobs to make sure the housing is watertight and the gland was installed properly. Check all controls while the housing is submerged.

 ***Caution:** If your housing has a shutter spring, **DO NOT** rotate the shutter control more than 1/16th of a rotation, otherwise, you may accidentally bend the shutter spring or cause the spring to “pop off” the control shaft.

Diagram F

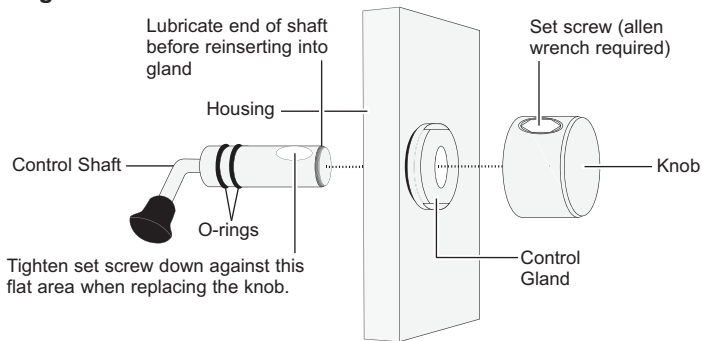

Diagram G

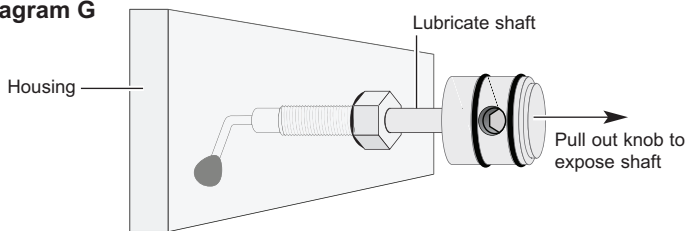

Diagram H

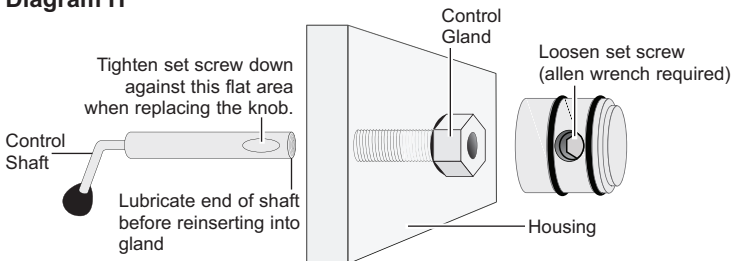



Photo Tips

- The number one rule in underwater photography is to eliminate as much water between the camera and subject as possible. Get as close as you can to the subject, then use the zoom. If you are using flash for still photos, subjects beyond 6 ft (1.8 m) will not have much color regardless of strobe power.
- Photograph in clear water; do not stir up the sand or silty bottom. If backscatter becomes a problem in the environment you are photographing, an external flash will help eliminate much of the backscatter.
- Many digital cameras have a slight lag time between when you press the shutter release button and the camera actually takes the picture. Hold the housing steady a second or two after pressing the shutter release button.
- Do not shoot down on subjects as they will quite often blend into the background and be difficult to see in the photograph. Shoot subjects straight on or shoot up at a slight angle using the blue water as a contrasting background.
- When using daylight or flash, if your camera consistently over or underexposes the image, you may want to adjust your camera's exposure compensation  settings.
- If you error in exposure, it is better to have the image slightly underexposed rather than overexposed. An overexposed image is missing color information which cannot be adjusted in a photo processing program. A slightly underexposed image has color information that can be adjusted.
- It is important to respect all living creatures underwater, including people, marine life, and coral. While we encourage people to get close to their subjects when taking a photograph, they should not touch, lie on, or in any way disturb the things they find underwater.

Troubleshooting

Problem	Solution
Push buttons or controls are sticky or hard to operate	<ul style="list-style-type: none">- Remove the camera and rinse the closed housing in fresh water. Vigorously press each push button in and out several times to release any trapped saltwater or debris.- Press a sticky push button all the way in and place a small amount of lube on the small end of the push button shaft at it's base. Release and operate the push button several times to distribute the lube, Diagram E, page 21.- If a larger gland style control is sticky, grab the control knob, pull it out, and then push back in. If still sticky, see the Control Maintenance section, pages 22-24.- Return housing to Ikelite for routine maintenance.
Image is over/underexposed, or a corner of the image is dark	<ul style="list-style-type: none">- Check that the built-in flash or external strobe is firing when taking a picture. Camera flash should be forced "on."- When using an external strobe, make sure it is turned on, set properly, and its battery is charged.- Make sure the diffuser is installed when you are NOT using an external strobe.- Check any corded connection points.- Change camera shutter speed or aperture.- Move closer to or further away from the subject.- Adjust Exposure Compensation .- If using a strobe, check deflector Fiber Optic hole alignment with Fiber Optic Ports.

Problem	Solution
Camera does not take a picture	<ul style="list-style-type: none"> - Install a fully charged battery. - There is not enough available light for the camera to properly focus. Add a focusing light or strobe with a built-in focusing or video light to your system. - Select a center focus point in your camera menu. - Return Zoom control to the “disengaged” position, see Zoom Control Use, page 12.
Housing is hard to close	<ul style="list-style-type: none"> - Make sure the camera is mounted properly in the housing and controls are out of the way. - Main housing o-ring is not seated properly.
Fogging occurs on the Lens Port	<ul style="list-style-type: none"> - Humid air is trapped inside the housing. The camera produces heat and may condense any trapped moisture forming fog on the lens port. Close the housing in an air-conditioned room or vehicle, or in front of an air-conditioner. - The housing should not be in direct sunlight for an extended period of time. - Purchase desiccant packs also known as moisture munchers from a local camera store. Place one or two new packs in your housing before each day of diving. - If moisture or water droplets are present around the controls or sealing areas, return the housing to Ikelite for evaluation. - Clean the main housing o-ring and sealing surface of the housing.

Problem	Solution
Water enters the housing	<ul style="list-style-type: none"> - Remove, clean and properly lubricate the main o-ring. - Look for hair, dirt, or foreign debris crossing the o-ring seal. - Reassemble the housing without a camera installed and immerse in water. - Return housing to Ikelite for evaluation.
Pictures are too blue or too green	<ul style="list-style-type: none"> - Use custom (manual) white balance. Reset for each working depth or when attaching a color correcting filter to the camera lens. - Add an external strobe. - Move in closer to your subject when taking a picture. - Add an optional color correcting filter to the Housing Port. - Strobe is not firing. Check corded connection points. Check deflector Fiber Optic hole alignment with Fiber Optic Ports.

Spare Parts (available through Ikelite or any Ikelite Dealer)

- 0132.30 Port o-ring
- 0200 Port cover
- 0184.2 Silicone Lubricant 2cc Reclosable Tube
- 0109 Main o-ring
- 9523.10 Tray Hardware

Customer Support

Please read the troubleshooting section of this instruction manual before contacting Ikelite Customer Support.

**Ikelite Underwater Systems
Service Department
50 West 33rd St.
Indianapolis, IN 46208 USA**

Email: ikelite@ikelite.com

Phone: 317-923-4523

Limited Warranty

This Ikelite product is warranted against any manufacturing defects for a period of one (1) year from the original date of purchase. Defective products should be returned to Ikelite postage paid. Ikelite will, at its sole discretion, repair or replace such products, and will return to customer postage paid. All other claims of any nature are not covered. Except as mentioned above, no other warranty expressed or implied applies to this Ikelite product.

Returning Products For Service

Ikelite is most interested in performing any service to ensure that all products perform as intended. Evidence of purchase date must be provided to obtain warranty service.

No prior authorization is required. You may return directly to us or through your dealer. Please include a brief description of the problem, any relevant email correspondence, and/or instructions on what you want us to do. Always include name, shipping address, email address, and phone number inside of the package. Send postage paid to:

**Ikelite Underwater Systems
Attention: Service Department
50 West 33 Street
Indianapolis, IN 46208 USA**

No reimbursements for postage paid will be issued.

You may also want to insure the package.

Returning Products for Service - outside the United States

For the separate international customs documentation form that you complete to accompany the shipment, please state or designate that the enclosed products were originally manufactured in the USA and are being returned to the manufacturer for repair service. Value of the equipment listed for customs purposes should be zero.

Product Registration

Please go to **ikelite.com** to register your Ikelite housing within 15 days of purchase.



**Ikelite Underwater Systems
50 West 33rd Street
Indianapolis, IN 46208 USA**

ikelite.com

© 2016 Ikelite Underwater Systems

6116.14_Sony_RX100III_RX100IV_RX100V_03-1116