



Digital Housing
i n s t r u c t i o n m a n u a l

for
Sony
DSC-F828

Housing
#6111.28

Ikelite Digital Housing

instruction manual

Housing #6111.28 for Sony DSC-F828



Congratulations on your purchase of an Ikelite Digital Camera Housing. Ikelite has over 30 years of experience in the underwater photographic and lighting market. Our products are designed and built in the USA by Ikelite for both the professional and amateur photographer.

The clear housing permits instant visual inspection of the camera and all sealing surfaces as well as complete monitoring of controls and camera LCD screens.

Ikelite Digital Housings are slightly negative in salt water for stability. This housing has been water pressure tested at the factory. Housing is pressure tested to 200' (60m).

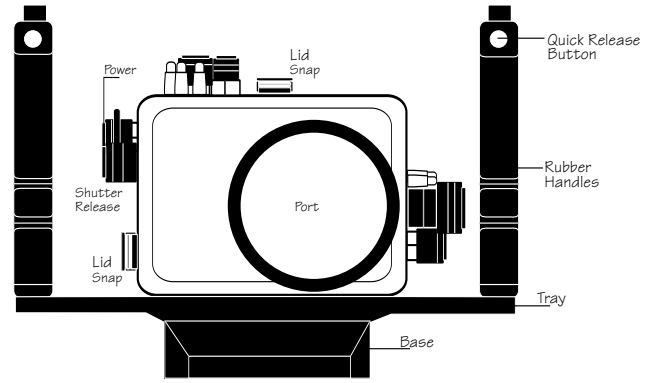

FRONT VIEW

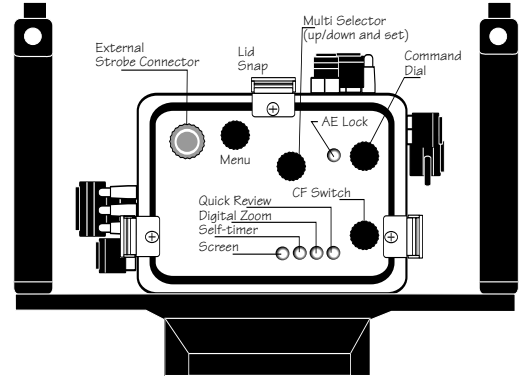

BACK VIEW

2

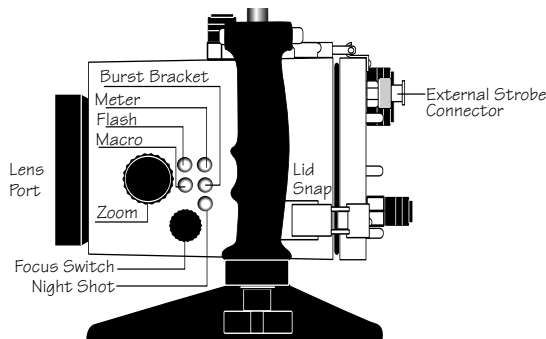

SIDE VIEW

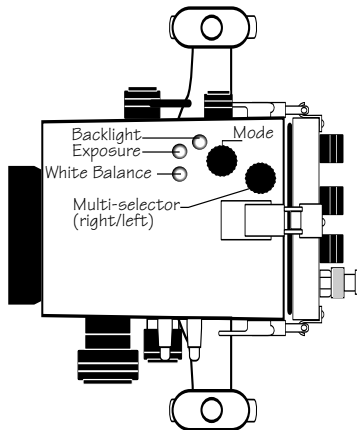

TOP VIEW

3

Opening the Housing

Lid Snaps have a **Lock**.

To open, push Lid Snap Lock forward and lift as shown. Keep pressure on the Lid Snap so it does not fly open quickly.

Some lid snaps have a lot of spring tension

once they go over center, have a firm grip on the lid snap. Lid Snaps may be opened one at a time.

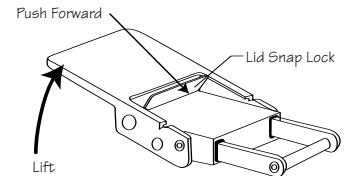

Installing Zoom Gear

To install the plastic Zoom Gear place the camera with the lens pointing up. Orient the Zoom Gear so the spring will be on the bottom of the lens when installed. Grasp each side of the Zoom Gear where the grooves stop and the smooth part starts. Pull out to expand the Zoom Gear and slide it over the lens zoom barrel.

Position the Zoom Gear so that it is centered (front to back) on the rubber around the zoom barrel as shown.

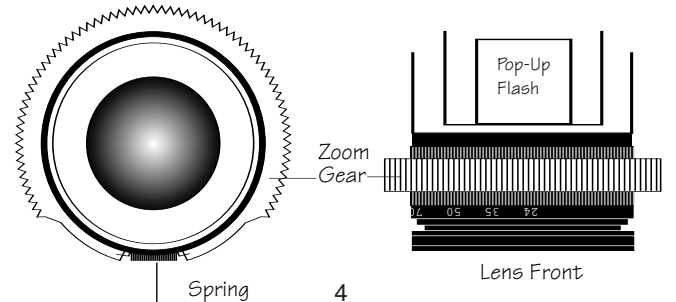

4

Secure Camera to Mounting Tray

Install a fully charged battery into the camera before securing the camera to the housing's mounting tray.

Remove the back from the housing. The mounting tray for the camera is secured to the housing back. Position the camera on the tray and secure it with the mounting bolt which threads into the camera's tripod socket.

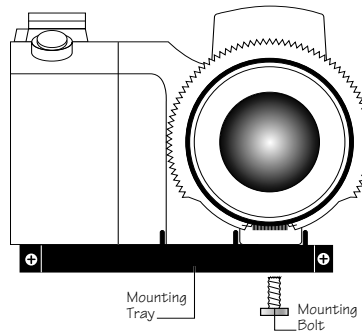

CAUTION:

Some camera tripod socket threads are plastic. The mounting bolt is metal. Do not cross thread or over tighten as you may damage the camera tripod socket threads.

5

Flash Connection

When using an external strobe connect the housings Hot Shoe Connector by sliding the connector into the accessory shoe of the camera from the back as shown. Slide the connector forward until it stops. This can be done after the camera is mounted to the mounting tray.

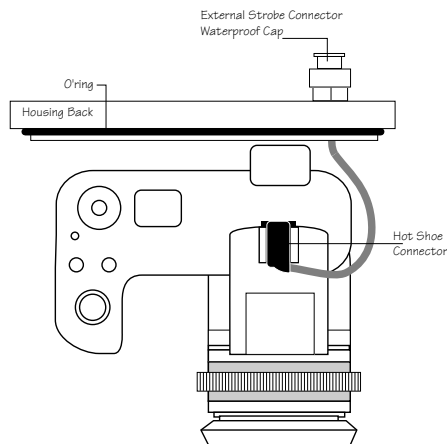

Caution

Only remove the WaterProof cap from the external strobe connector on the back of the housing when an external strobe will be connected.

Installing the Camera into the housing

Pull out on each of the housing's controls that have a knob. This will get the controls out of the way for easier camera installation.

7

Using Flash

The camera's built-in flash cannot be used.

External Flash

An external strobe offers several advantages over using the camera's built-in flash. External strobes move the flash away from the camera lens which helps reduce backscatter. They also expand lighting options to achieve the best lighting for different subjects. A second external digital strobe package can be added to fill the shadows and produce more realistic photographs.

Option 1

Use any Ikelite Substrobe in the manual mode.

The housing provides a Hot Shoe connector and an external strobe connector to connect external strobes. A sync cord is required to connect the housing's strobe connector to the strobe.

Option 2

Use an Ikelite EV-Controller which offers 10 manual power settings in 1/2 stop increments for precise illumination of macro or wide-angle subjects. The EV-Controller requires no batteries and is compatible with pre-flash and non pre-flash cameras. The EV-Controller can only be used with Ikelite DS Substrobes. A sync cord is required to connect the EV-Controller to the camera housing.

6

Closing the Housing

1. Check to see that there is an o'ring on the housing back and that it is clean and in its proper location.
2. Place housing with the port pointing down in your lap or on a flat surface.
3. Guide the back onto the housing. The o'ring should touch the housing all the way around. There should be an even gap all the way around between the housing and the housing back.
4. Lift the lid snaps so they are extended and place the lid snap into the hook on the housing back.
5. To close the housing push down on the lid snaps until they snap into place. Lid snaps on opposite sides of the housing should be closed at the same time. Be sure they are down far enough to engage the lock.

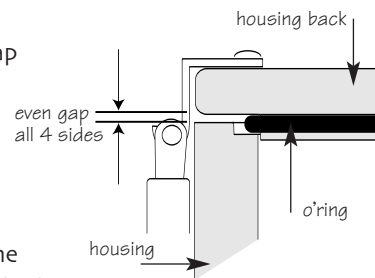
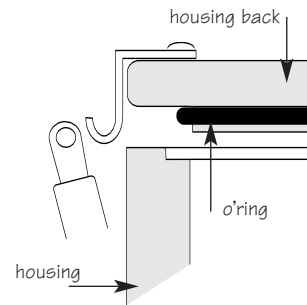

Double check

Once the housing is closed, check the o'ring seal. Check the gap between the housing back and the housing, it should be even all the way around. Look through the clear plastic back at the o'ring. You should see a darkened area where the o'ring is compressed against the housing back. If you do not see an even black compression seal all the way around the back, open the lid snaps, reseal the housing back and close the lid snaps. Visually check the seal again.

8

Checking Controls

Once the housing has been closed, push the controls back into place. Make sure they line up with the camera's controls.

Turn Camera On

Turn the camera on and operate each of the housing controls to get a feel for using the camera in the housing. Take a few pictures above water with the camera in the housing.

Note: Multi-selector control on the back of the housing toggles camera's Multi-selector up and down. Once the desired menu item is selected pull out on this control, center it on the Multi-selector button and depress to set the desired function.

Lens Port

The Lens Port is factory sealed, do not remove.

Treat the glass in the lens port as a camera lens. After use, rinse and gently dry the lens port to avoid water spotting. To clean use a mild soap solution or lens cleaner.

Do not use alcohol or window cleaner on the Lens Port.

Lubricants

1. Ikelite provides silicone lubricant with the housing. We recommend that you use only Ikelite lubricant on Ikelite products as some other brands may cause the o'ring to swell and not seal properly.
2. Use only enough lubricant to lightly cover control shafts and o'rings. Wipe off any excess lubricant with a clean cloth. Lubricant is not a sealant, it is used to reduce friction. Excessive lubricant can collect sand and dirt which may interfere with proper sealing.

CAUTION

Never use spray lubricants as the propellant ingredient can cause the plastic housing to crack.

9

Maintenance

The Ikelite Digital Housing should be given the same care and attention as your other photographic equipment. In addition to normal maintenance we recommend that the housing be returned to Ikelite periodically to be checked and pressure tested.

1. **Do Not** leave the camera and housing in direct sunlight for prolonged periods. Heat may damage the camera.
2. **Do Not** ship the camera in the housing.
3. Before using the housing, always check the tightness of the **set screw** in each control knob.
Check each **control gland** penetrating the housing to make sure they are tight. There is a slight chance that either could vibrate loose during travel.
4. Keep the back o'ring clean and lightly lubricated. To lubricate remove the o'ring from the back. Put a small amount of Ikelite lubricant on your fingers. Draw the o'ring through your fingers to apply a light coating of lubricant. Only apply enough lubricant to make the o'ring feel slick. **Do Not stretch the o'ring.** This light coating of lubricant will help to keep the o'ring from drying out and will help to show a dark sealing line when the housing back is properly sealed.
5. Keep the area where the o'ring fits and the sealing surface of the housing clean.
6. Rinse the housing exterior thoroughly in fresh water after each salt water use. Dry with a soft cloth. Dry lens port to eliminate water spotting.
After several uses in salt water soak the housing in a mild soap solution, rinse and dry before storage. When storing the housing, remove the back o'ring, lightly lubricate and place in a plastic bag. Place the plastic bag with o'ring inside the housing for safe keeping.

CAUTION

Never use spray lubricants as the propellant ingredient can cause the plastic housing to crack.

11

Quick-Release Base, Handles and Tray

Quick-Release Base

The Quick-Release Base is plastic. A toggle lever located underneath the base allows the base to be easily removed from the Tray. Turn the housing upside down, pull out on the toggle lever. Rotate the lever 90° to remove the base.

Handles and Tray

The housing handles are rubber and the tray is aluminum. Their weight helps to offset the buoyancy of the housing. The complete assembly is slightly negative underwater for better control. The handles have a push button release for easily attaching and removing strobe arms. The tray and handles can be removed from the housing. To remove the tray, the base must be removed to gain access to the nuts holding the tray on the housing. Remove the 2 nuts, washers and rubber spacers. **DO NOT** remove the bolts protruding through the housing.

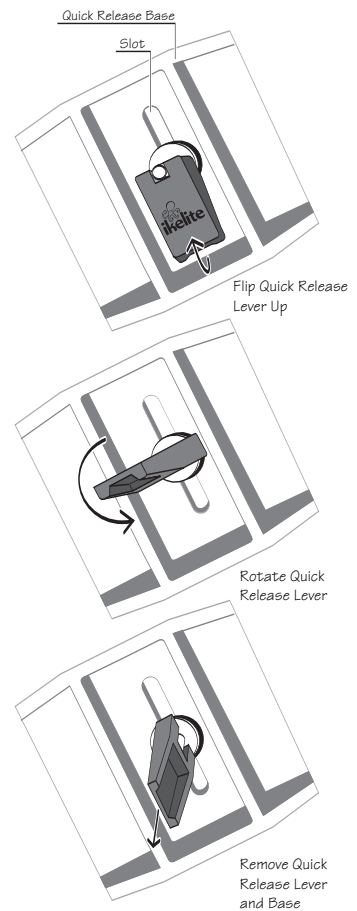

10

Control Maintenance

Ikelite controls are designed to provide years of reliable service with minimal maintenance.

1. Push button controls require no maintenance other than rinsing in fresh water after saltwater use. If a push button control becomes difficult to push or if it sticks when depressed, soak the housing in luke warm fresh water. After a few minutes operate the push button. If this does not correct the problem, return the housing to Ikelite for maintenance.
2. Some of the controls have long shafts. These controls can be

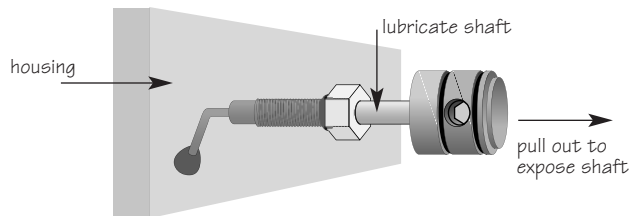

pulled out, exposing the shaft (see drawing).

To lubricate the control, gently pull on the knob until the stainless steel shaft is exposed. Lightly lubricate the shaft, then move the shaft in and out several times. This will lubricate the x'ring in the Ikelite control gland. This should be done before using the housing after a prolonged storage period, or once a week when the housing is in use.

12

3. Some of the controls have a short shaft and cannot be pulled out exposing the shaft for lubrication. In the unlikely event one of these controls sticks or becomes difficult to operate you can remove the control from the housing and lubricate it, or return the housing to Ikelite for maintenance. To remove the control, loosen the set screw in the knob (allen wrench required); remove the knob. If there is salt or dirt build-up on the exposed control shaft, clean the shaft. Open the housing and gently slide the control shaft out of the control gland. Clean and lightly lubricate the shaft, including the end of the shaft. Slide the shaft back into the control gland and gently slide it back and forth a few times without fully removing the shaft from the gland. Replace the knob, NOTE the flat area on the shaft, the set screw in the knob should tighten down against the flat area on the control so the knob does not turn on the shaft.

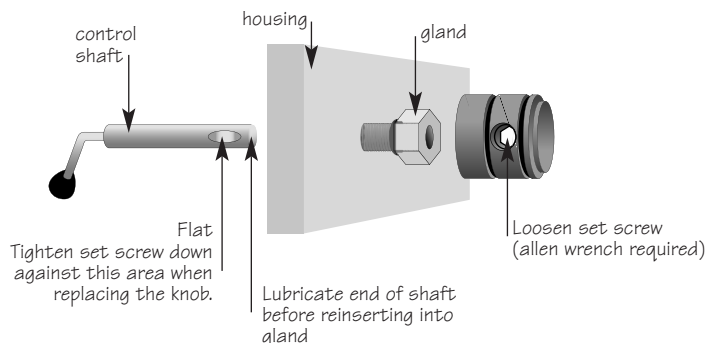

13

Optional Accessories

Back O'ring #0132.59

O'rings last for several years if properly maintained. (See maintenance) Always carry a spare.

External Strobes

Substrobe DS51 #4044

Substrobe DS125 #4065



Sync Cords

Single strobe #4103.51

Dual Strobe #4103.52

Strobe Arms

Strobe Arm #4075.1

SA-100R Arm #4085.51

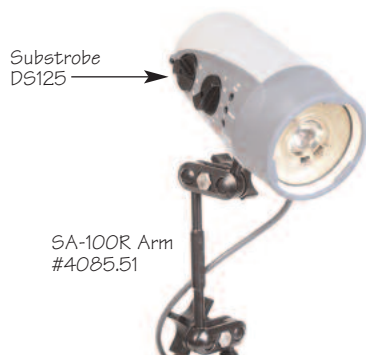

14

Photo Tips

1. The number one rule in underwater photography is eliminate as much water between camera and subject as possible. Get as close as you can to the subject, then use the zoom. If you are using flash, subjects beyond 6 feet (1.8m) will not have much color.
2. If the camera's built-in flash is being used it is very close to the camera lens. The flash will light up any suspended particles in the water and they will be recorded in your picture. This effect is called backscatter. To eliminate as much backscatter as possible, photograph close. Photograph in clear water; do not stir up the sand or silty bottom. If backscatter becomes a problem in the environment you are photographing, an external flash will help eliminate much of the backscatter.
3. Digital cameras have a slight lag time between when you press the shutter release button and the camera actually takes the picture. Hold the camera steady a second or two after pressing the shutter release button.
4. Do not shoot down on subjects as they will quite often blend into the background and be difficult to see in the photograph. Shoot subjects straight on or shoot up at a slight angle using the blue water as a contrasting background.
5. Underwater flash is used to restore the warmer colors filtered out by the water as well as to illuminate the subject. When photographing underwater, set the camera to use flash on every shot. If the camera's flash is set to AUTO and the sun is behind your subject, the camera may see enough light that it does not fire the flash. With the sun behind the subject the subject is shaded (dark) and needs flash for a good exposure.

15

Ikelite Limited Warranty

All Ikelite products are warranted against any manufacturing defects for a period of one (1) year from the date of purchase. Defective products should be returned prepaid to Ikelite. Ikelite will, at its discretion, repair or replace such products, and will return to customer prepaid. All other claims, of any nature, including but not limited to bulb failure are not covered. Except as mentioned above, no other warranty expressed or implied, applies to this Ikelite product.

Returning Products for Service

Ikelite is most interested in performing any service to assure that all products perform as intended. For repair or service, return the product to the address below with your name, address, phone number and a brief description of the problem. Evidence of purchase date must be provided to obtain warranty service.

**Ikelite Underwater Systems
50 W 33rd Street
Indianapolis, IN 46208 USA**

317-923-4523

**email: ikelite@ikelite.com
www.ikelite.com**

Digital 6111.28-01-0304