



Vacuum Kit for Control Gland 3/8" Holes

Product number 47013

Vacuum Valve for Control Gland 3/8" Holes

Product number 47003

Product Registration

Please register your product at ikelite.com within 15 days of purchase. Our product registration database is the best way for us to get a hold of you in the event of a product update or notice.

About this Product

Thank you for your purchase of Ikelite equipment. Please read this instruction manual completely before attempting to operate or dive with this product. Please visit ikelite.com to register your product to receive information on any updates, notices, or recalls pertaining to your equipment.

Included in the Box

- Vacuum valve for 3/8" holes
- Vacuum valve plug with retainer
- O-ring # 0102
- Hex nut # 0219.2
- Vacuum pump with gauge # 47011 (included in 47013 only)

Important Notices

- » **The vacuum valve is only waterproof with the plug in place. Never submerge the housing in water without the plug properly installed in the valve.**
- » **Vacuum systems are only capable of simulating depths up to 33 feet (10 meters). Some very small leaks, like those caused by a fine hair across the o-ring, may only occur at deeper depths. In most cases, these leaks are not significant enough to cause damage to a camera.**
- » **A vacuum system cannot correct for improper assembly.**

Contents

Product Registration	1
About this Product	2
Included in the Box	2
Important Notices	3
Getting to Know Your System	5
Installing the Vacuum Valve	6
Removing a Control.....	6
Installing the 3/8" Valve	7
Using the Vacuum System	8
Getting Ready for a Dive.....	8
Final Check.....	10
Opening the Housing.....	10
Limited Warranty	11
Service and Repairs	11
Contact Us	12

Getting to Know Your System

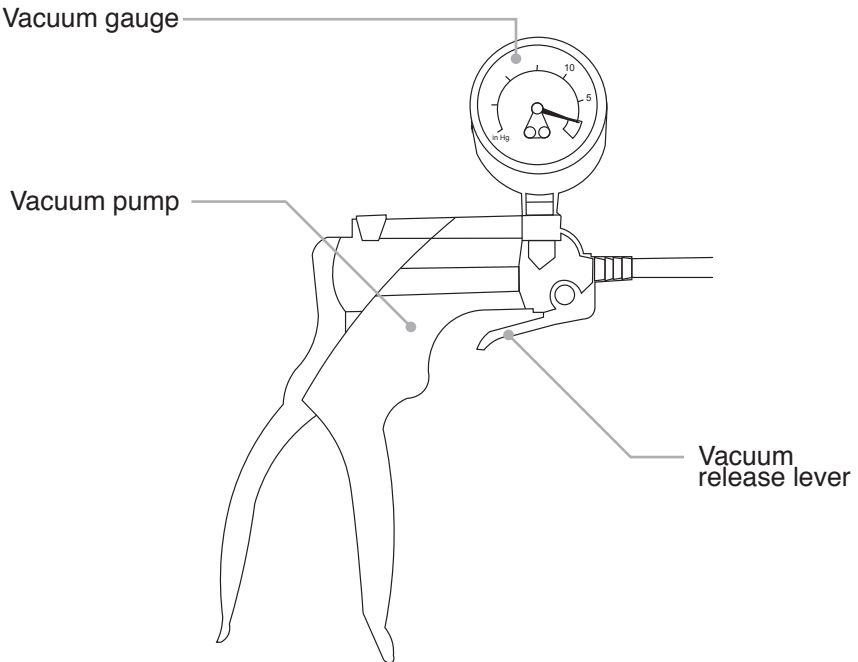
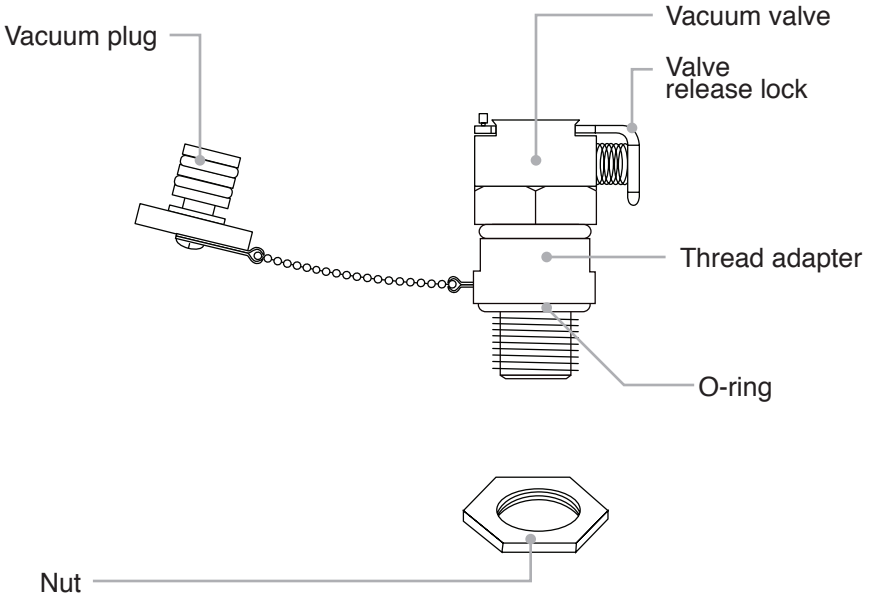

Installing the Vacuum Valve

Removing a Control

- » The 3/8" valve can only replace rotating or lever type controls with knobs on the front half of the housing. The 3/8" valve cannot be used on the housing back.
- » The 3/8" valve cannot be used in place of a push button or the DSLR top mount.

1. If the knob has a lever with vinyl rubber cover, remove the cover from the lever by turning it counter-clockwise.

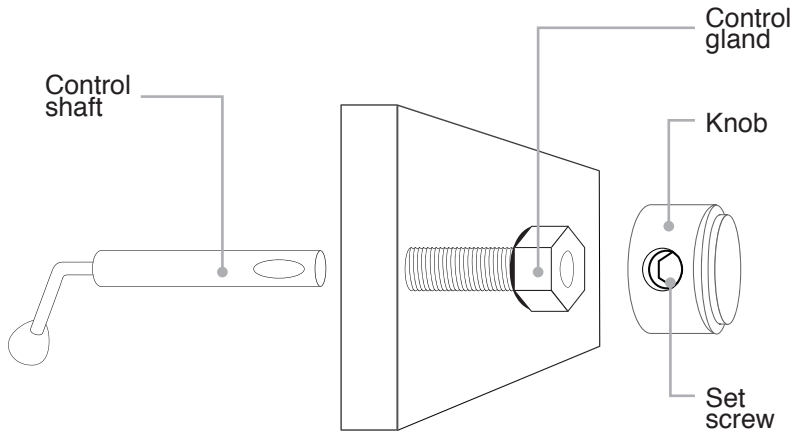

2. Use an 1/8" hex key to loosen the set screw holding the knob onto the control shaft.
3. Remove the knob.
4. Remove the control shaft from the inside of the housing.
5. If there is a nut on the inside of the control gland, remove it using a 9/16" wrench.

6. Remove the control gland from the housing using a 5/8" wrench. If the hex gland cap separates from the body during removal, use a pair of pliers to carefully remove the gland body from the housing.
7. Clean the surface of the housing where the control was removed using a soft, lint-free cloth.

Installing the 3/8" Valve

- » **Do not attempt to separate the vacuum valve from the thread adapter. Do not attempt to remove the o-ring from between these two pieces.**
1. Make sure that the o-ring is in place on the valve body. Do not lubricate the seal ring prior to installation.
 2. Thread the valve into the housing and hand tighten.

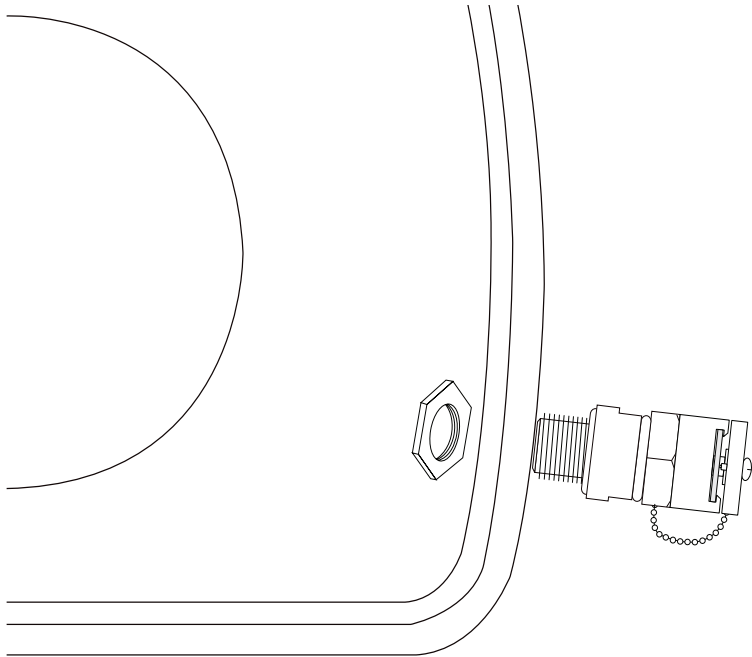

3. Tighten the valve until snug using an open-ended 9/16" wrench on the thread adapter portion of the assembly. Do not over-tighten.

4. Attach the nut to the thread adapter on the inside of the housing and tighten until snug. Do not over-tighten.

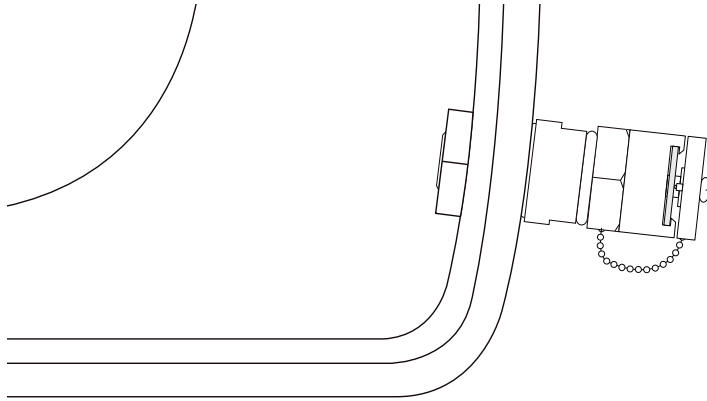

Using the Vacuum System

Getting Ready for a Dive

- » **The housing is only waterproof with the vacuum valve plug in place. Always replace the valve plug before putting the housing in water.**
1. Install your camera in the housing according to the housing's instructions.
 2. Press the vacuum valve lock release and remove the plug from the valve.

3. Attach the vacuum pump tubing insert into the valve and push until it clicks and locks in place.

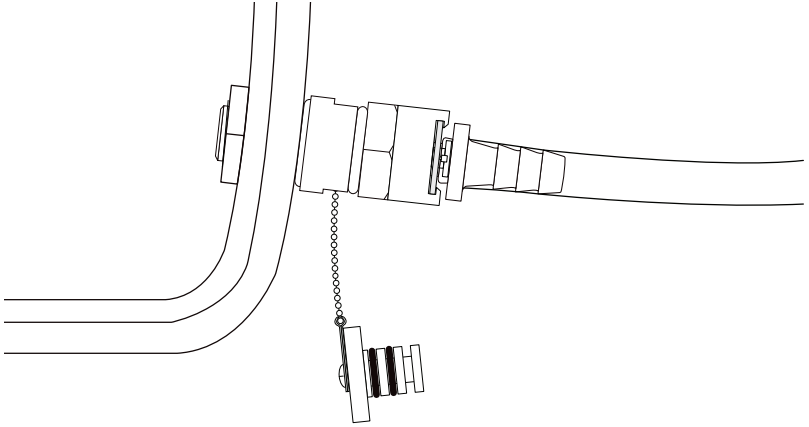

4. Rotate the vacuum gauge so that it can be easily read while pumping. Pump the hand pump until the vacuum gauge reaches 5-10 inches Hg.

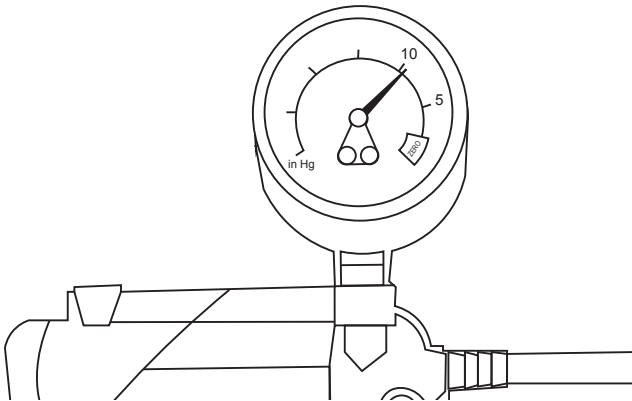

5. Watch and listen for leaks. A leak is indicated by movement of the gauge towards zero after you finish pumping. Significant leaks can generally be found within a few minutes.
6. Press the lock release and remove the vacuum pump from the valve.

7. Install the valve plug into the valve and push until it clicks and locks in place.
8. If desired, re-attach the pump after letting the system sit for hours or overnight. Check that the gauge returns to the same position as when the system was assembled. Very small leaks will become more evident on the gauge as more time passes.

Final Check

1. Turn on the camera and check all control functions.
2. Make sure the camera can take and record a photo.
3. Check battery life and open storage space on your memory card.
4. Check your external flash or lighting, if using.
5. Submerge the housing in a fresh water tank dedicated to underwater photography equipment. Visually confirm that there are no signs of water intrusion. One sign of a leak is a steady stream of bubbles coming from one of the housing's seals.

Opening the Housing

» **It is not possible to open the housing normally when a vacuum is pulled on the housing. The vacuum must be released prior to opening the housing.**

1. Rinse the housing with fresh water and dry prior to opening.
2. Press the vacuum valve lock release and remove the plug from the valve.
3. Attach the pump to the valve and press the release lever on the pump.
4. If the pump is not available, insert a small blunt object into the center of the valve and gently press to allow air to enter the housing.

Limited Warranty

This Ikelite product is warranted against any manufacturing defects for a period of one (1) year from the original date of purchase. Defective products should be returned to Ikelite postage paid. Ikelite will, at its sole discretion, repair or replace such products, and will return to customer postage paid. All other claims of any nature are not covered. Except as mentioned above, no other warranty expressed or implied applies to this Ikelite product.

Service and Repairs

Ikelite is most interested in performing any service to ensure that all products perform as intended. Evidence of purchase date must be provided to obtain warranty service.

No prior authorization is required. You may return directly to us or through your dealer. Please include a brief description of the problem, any relevant email correspondence, and/or description of the service request. Always include name, shipping address, email address, and phone number inside of the package. Send postage paid to:

Ikelite Underwater Systems
Attention: Service Department
50 West 33rd Street
Indianapolis, IN 46208 USA

For the separate international customs documentation form that you complete to accompany the shipment, please state or designate that the enclosed products were originally manufactured in the USA and are being returned to the manufacturer for repair service. Value of the equipment listed for customs purposes should be zero.

Contact Us

If you have any questions about your product or need advice on getting the images you want, please get in touch with us and we'll do everything we can to help you capture your unique perspective.

Ikelite Underwater Systems
50 W 33rd St
Indianapolis, IN 46208 USA
(317) 923-4523
ikelite@ikelite.com