



Underwater Housing for Sony Cyber-shot RX100 Mark I, Mark II

Product Number 6116.17

Product Registration

Please register your product at ikelite.com within 15 days of purchase. Our product registration database is the best way for us to get a hold of you in the event of a product update.

About this Product

Thank you for your purchase of Ikelite equipment. Please read this instruction manual completely before attempting to operate or dive with this product. Please visit ikelite.com to register your product to receive information on any updates, or notices pertaining to your equipment.

Included in the Box

- Housing
- Port cover # 0200
- Silicone lubricant 1cc tube

Specifications

- 200 ft (60m) depth rating
- Controls for all camera functions except Flash switch and Viewfinder switch
- Slightly negative buoyancy in fresh water
- 1/4-20 thread tray mounting with 3 in (76mm) spacing
- Weight 2.6 lb (1180 g)
- Dimensions 6.8 x 5 x 5.4 in (173 x 127 x 137 mm)
- 3.0-inch diameter glass lens port

Important Notices

- » Never leave a housing in a rinse tank, even if it is the only system in the tank. The vast majority of catastrophic floods happen when the user walks away from a housing while it is in the rinse tank.
- » To prevent salt build-up and sticking controls, submerge the empty housing in clean, freshwater. Operate the controls several times each while underwater to flush out any residue.
- » Do not use alcohol, cleaning agents, spray lubricants, Rain-X, or other solvents on the housing or lens port. Use of an incompatible chemical compound can damage the plastic and o-rings, and may result in leaking.
- » This housing is designed to work with both the RX100 I and RX100 II camera models. Camera Mounting Plates are different for each camera model and are marked accordingly. The housing is boxed with the RX100 II Mounting Plate in the housing. The RX100 I Mounting Plate will be in a bag with a Small Pad that must be added to the rear dial for proper operation. To attach the small pad, remove adhesive backing and press pad tightly onto the existing Rear Dial Pad as shown below. DO NOT attach the pad when using the RX100 II.

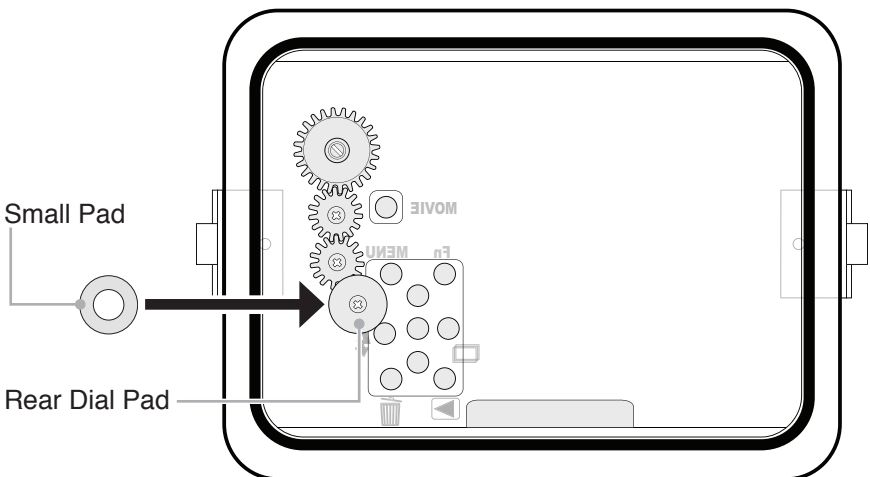

Contents

| | |
|---|-----------|
| Product Registration | 1 |
| About this Product | 2 |
| Included in the Box | 2 |
| Specifications | 2 |
| Important Notices | 3 |
| Getting to Know Your Housing | 5 |
| Getting to Know Your Housing - cont..... | 6 |
| Accessory Port..... | 7 |
| Setting Up Your Camera | 7 |
| Pre-Installation Checklist & Initial Camera Settings..... | 7 |
| Setting Up Your Housing | 8 |
| Opening the Housing..... | 8 |
| Inserting the Camera..... | 9 |
| Closing the Housing..... | 10 |
| Final Check..... | 11 |
| Entering the Water..... | 12 |
| Built-in Flash and External Strobe Use | 12 |
| About the Built-In Flash..... | 12 |
| Attaching a Fiber Optic Cord..... | 13 |
| Wide Angle, Macro & Filters | 14 |
| Spare Parts | 14 |
| Maintenance | 15 |
| Post-Dive..... | 15 |
| Travel and Storage..... | 15 |
| Troubleshooting | 16 |
| Limited Warranty | 18 |
| Service and Repairs | 18 |

Getting to Know Your Housing

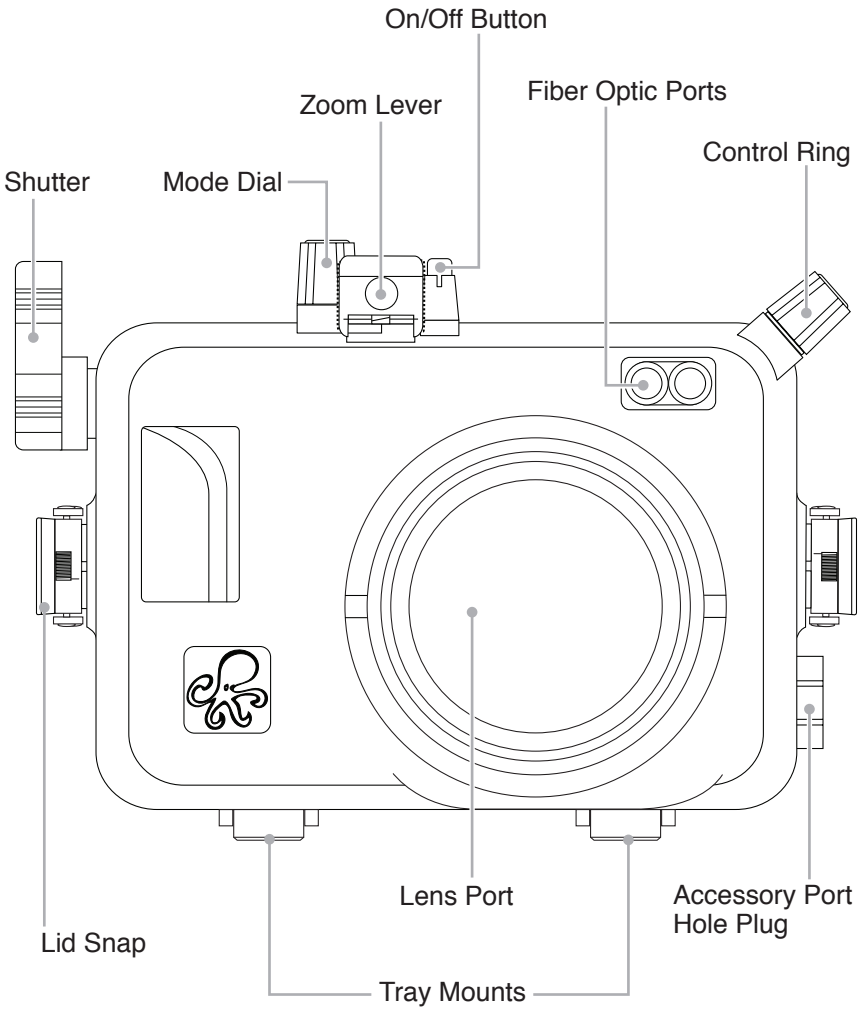

Getting to Know Your Housing - cont.

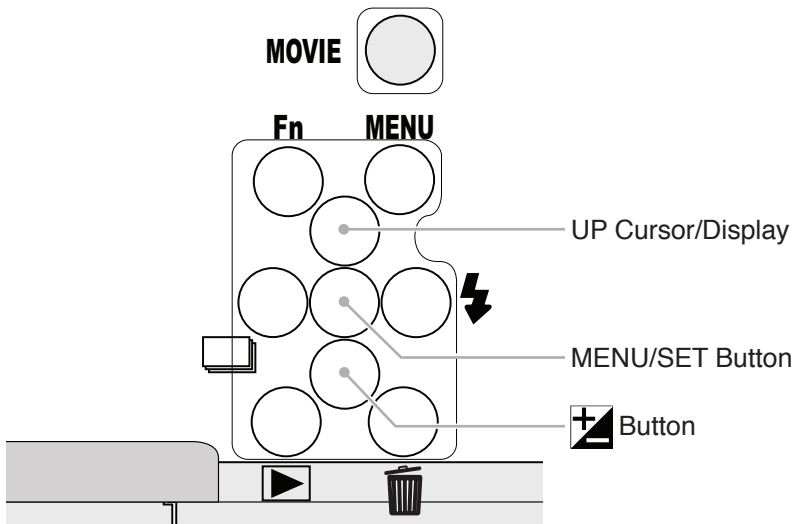
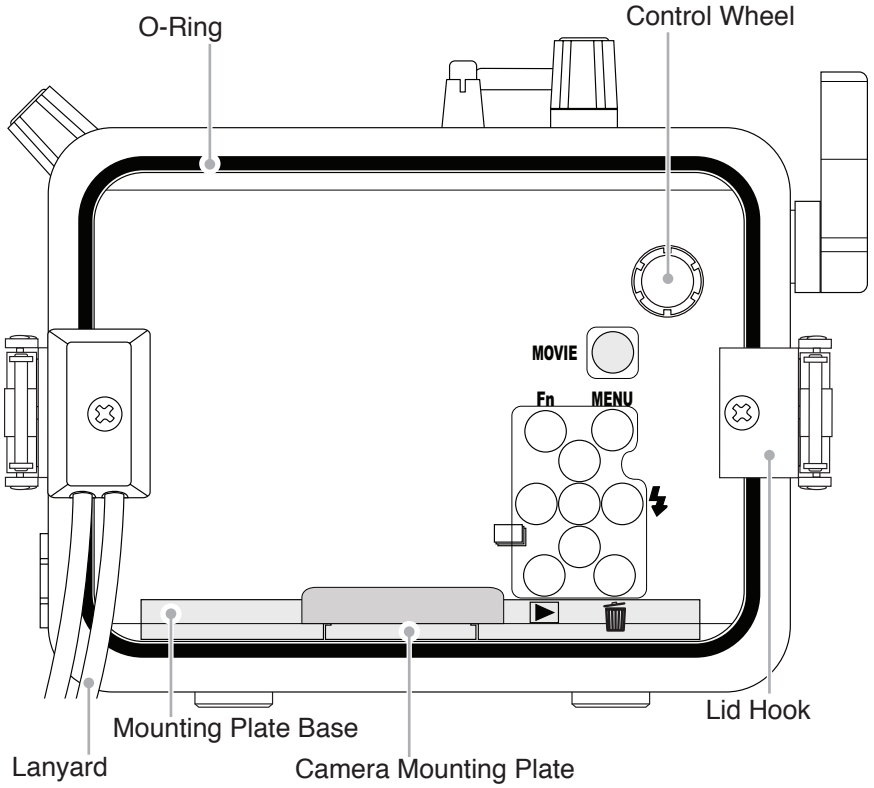

Accessory Port

Your housing features one 1/2-20 threaded Accessory Port which may be used for attachment of factory optional or aftermarket housing accessories. Visit ikelite.com for an updated list of factory optional accessories.

Use the following steps to replace an Accessory Port Hole Plug with an accessory fitting:



1. Remove the Hole Plug using an 11/16 inch open end wrench.
2. Check the accessory fitting o-ring sealing area. If an o-ring is not present, use the Hole Plug o-ring. Lightly lubricate o-ring with Ikelite Lubricant. Use ONLY Ikelite lubricant. Other manufacturer lubricants can cause the o-ring to swell. Check o-ring and o-ring sealing area. Both should be clean and free of hair, sand, or other debris.
3. Carefully screw in and tighten accessory fitting. The accessory port features a 1/2-20 threaded hole. Make sure your fitting is the same thread pattern. DO NOT cross-thread. DO NOT overtighten.

 **NOTICE:** Your Ikelite housing warranty DOES NOT extend to cover the attachment of aftermarket housing accessories by 3rd parties. Warranty DOES cover factory optional accessories attached by certified Ikelite service technicians.

Setting Up Your Camera

Pre-Installation Checklist & Initial Camera Settings

1. Insert a fully charged camera battery.  The Camera Mounting Plate must be removed to access the battery door.
2. Insert a properly formatted memory card.

3. Set Mode Dial to “A” Aperture Priority. Manually adjust aperture setting to achieve the best exposure for your shooting conditions. The shutter speed will be locked at 1/30th second. If a faster shutter speed is desired, set Mode Dial to “M” Manual mode to manually adjust both aperture and shutter speed settings.
4. Set Drive Mode to “Single Shooting” and Flash Mode to  “Fill Flash.”
5. Set Focus Mode to “Single-shot AF” and AutoFocus Area to “Center.”
6. Set ISO to “200” and Metering Mode to “Center.”
7. Set White Balance to “AWB” Auto WB. When recording video or NOT using a strobe, AWB can still be used, however, for more accurate and consistent colors we recommend setting “Custom white balance”  .
8. Set AF Illuminator to “Off.”
9. Set Red Eye Reduction to “Off.”
10. Set Auto Review to “5 Sec.”
11. Set Power Saving Tart Time to “5 Min.”

All camera user settings not listed should be set to the user’s preference. Adjust settings as necessary for each shooting situation.

Setting Up Your Housing

Opening the Housing

1. Push the lid snap lock forward and start to lift the curved end away from the housing.

2. Lid snaps are designed to provide enough force to compress the o-ring for a proper seal. Keep firm pressure against the lid snap while lifting it away.

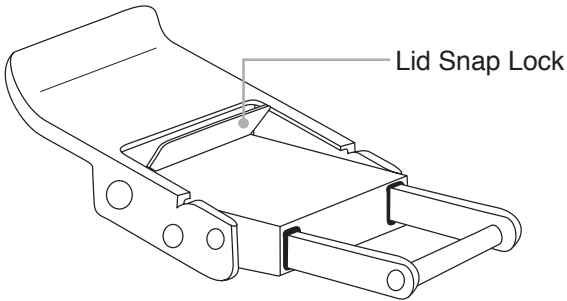

3. Repeat with remaining lid snaps.
4. Remove the housing back.

Inserting the Camera

1. Remove any lanyard or neck strap which may be attached to the camera.
2. Remove the camera Mounting Plate from the housing.

3. Line the mounting screw up with the camera's tripod socket. Open the camera's rear LCD screen slightly to allow the Mounting Plate to sit flush on the bottom of the camera. Use a coin or flat head screwdriver to tighten the mounting plate to the camera.

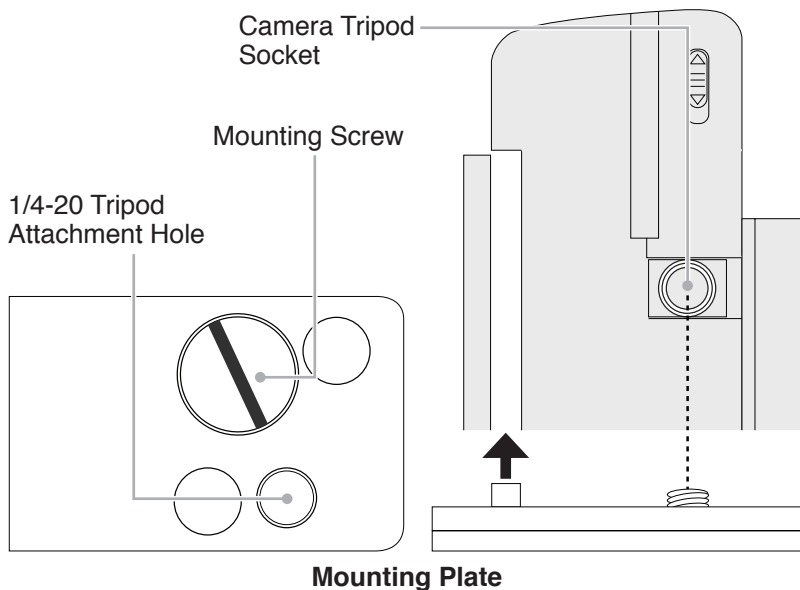

4. Pull out on the housing control knobs to move them out of the way.
5. Insert the mounting plate into the slot on the inside bottom of the housing. Push the camera all of the way forward until the back of the mounting plate is flush with the Mounting Plate Base.

Closing the Housing

1. Make sure the o-ring is clean and in its proper location on the back of the housing. The main o-ring does not require lubricant to make a seal.
2. Place the back onto the housing front.
3. Make sure no controls or wires are interfering with the o-ring or the back of the housing.

4. Place each lid snap into the corresponding hook on the housing back.
5. Push the lid snaps towards the housing until they are flat against the housing and the lock has engaged. Close opposing lid snaps at the same time.
6. Check the o-ring seal. The o-ring should form a uniform, solid line around the back of the housing. There will be a small, even gap around the housing between the housing back and the housing front.

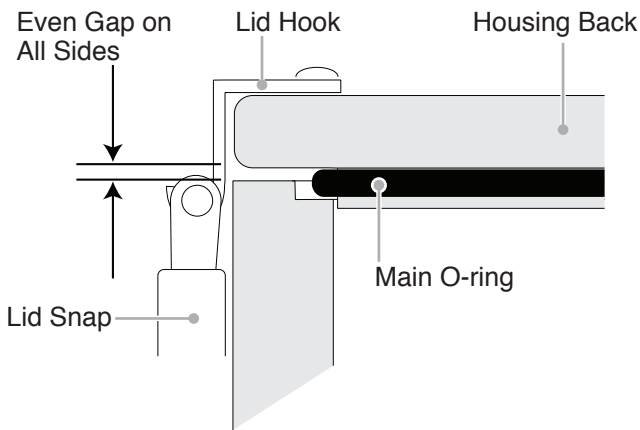

Final Check

1. Re-check the o-ring seal. The seal should form an even, solid line around the back of the housing.
2. Turn on the camera and check all control functions.
3. Make sure that the camera can obtain focus and take a photo.
4. Check battery life and open storage space on your memory card.
5. Check the flash if connecting a strobe.

6. Submerge the housing in a fresh water tank dedicated to underwater photography equipment. Visually confirm that there are no signs of water intrusion or a steady stream of bubbles coming from one of the housing seals.

Entering the Water

1. If possible, we recommend entering the water without your housing to ensure that you are comfortable and your life-saving equipment is in working order. Once you are stable, have someone pass your camera housing to you.
2. Submerge the housing at the surface of the water and visually confirm that there are no signs of water intrusion or a steady stream of bubbles coming from one of the housing's seals. If water does appear to be entering the housing, point the lens port downward and return the housing to the surface as quickly as possible. Please observe all necessary safety precautions. NEVER ascend faster than accepted safety limits.
3. Use your hand to gently flush away any small bubbles that may be on the face of the lens port. Bubbles will produce soft focus spots in your photo or video.

Built-in Flash and External Strobe Use

About the Built-In Flash

Due to the opaque housing design, the internal "built-in" flash can ONLY be used to trigger external fiber optic strobes. For the best color and clarity, we recommend adding a filter, strobe, or constant-on light. To shoot flash photography underwater, an external strobe must be connected to the housing and then triggered via fiber optic cord. Two ports are provided for the connection of up to two fiber optic cords. Any Ikelite DS strobe may be connected using the Fiber Optic Converter # 4401.1 and Fiber Optic Cord # 4501. The AF35 strobe is NOT compatible with this housing.

We recommend attaching an external strobe for the optimal color and clarity in a wide variety of shooting situations, including daylight photography.

Attaching a Fiber Optic Cord

1. Check the end of the fiber optic cord to ensure that it is clean and smooth.
2. Ensure that the fiber optic cord o-ring is in place. This o-ring does not provide waterproofing, however it does keep the fiber optic cord in place.
3. Attach one end of the fiber optic cord into one of the fiber optic ports on the front of the housing. The connector is a press-fit into the fiber optic port.

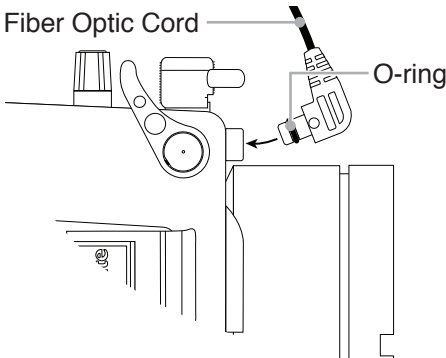

4. Attach the other end of the fiber optic cord to a compatible strobe.
5. Set the strobe to the appropriate setting based on manufacturer recommendations.
6. Turn the camera on and pop up the built-in flash.
7. Turn the strobe(s) on.
8. Take a test photo to ensure that your strobe(s) are functioning properly.

Wide Angle, Macro & Filters

Our 3-inch diameter ports feature a 67mm thread on the front for the easy attachment of external wide angle and macro wet lenses. Wide angle lenses make objects appear smaller, so that you can fit more into your frame underwater. Macro close-up lenses make small objects appear larger, so that tiny creatures will fill your frame.

The WD-3 Wide Angle Dome provides mid-range angle of view with no vignetting (dark shadows in the corners of the image).

The W-30 Wide Angle Lens, INON UWL-H100, and other 67mm threaded wide angle lenses, provide a wider maximum angle of view. Because these are separated from the camera's lens by glass, air, and water, some vignetting and edge distortion will be present. These effects can be reduced or eliminated by using a smaller aperture, zooming in slightly, and/or cropping in post-production.

External macro lenses with 67mm threads from INON, Epoque, and other manufacturers, can be attached directly to the front of the housing's port.

3-inch diameter color filters press directly onto these ports. Most wide angle lenses require a 3.6-inch diameter color filter. Refer to the product web page for information on color filter compatibility.

Spare Parts

- 0109 Main o-ring
- 0119.2 Port o-ring
- 0200 Port cover

Maintenance

Post-Dive

1. Rinse the housing in fresh water. Rotate the housing controls and press each button while submerged in fresh water to flush out any salt or debris to ensure smooth operation on future dives.
2. NEVER leave your housing in the fresh water rinse tank. Collisions with another person's gear can cause scratches or damage to your equipment.
3. Stow the housing in a shaded place where it is protected from impact or overheating. If no shade is available, we recommend covering the housing with a towel or cloth.
4. Check the memory card capacity and battery life of your camera and strobe(s). Recharge as necessary.
5. Always re-check o-ring seal after opening the housing.

Travel and Storage

1. Remove the camera from the housing for travel or storage.
2. Check the main housing o-ring.
3. Close the empty housing and submerge in lukewarm fresh water. While submerged, rotate each control and depress each button to flush out any salt or debris.
4. Remove the housing from water and rinse with running water.
5. Do not rinse the inside of the housing or submerge the open housing in water. If the inside of the housing needs to be cleaned, wipe with a clean, slightly damp cloth.
6. Dry the housing with a clean, lint-free cloth.
7. Store in a cool, dry place.

8. Like regulators and other pressure-sensitive equipment, we recommend careful care and cleaning along with annual replacement of the factory seals.

Troubleshooting

Water enters the housing

- Re-clean and re-install the main o-ring.
- Take the housing underwater without a camera installed to ensure that the leaking has been corrected.

Photos are over-exposed (too light)

- Adjust aperture (smaller), shutter speed (faster), or ISO (lower) setting.
- Move light(s) farther away from your subject.
- Adjust exposure compensation in the camera.
- Adjust lighting power.

Photos are under-exposed (too dark)

- Adjust aperture (larger), shutter speed (slower), or ISO (higher) setting.
- Move light(s) farther away from your subject.
- Adjust exposure compensation in the camera.
- Adjust lighting power.

Strobe will not fire

- Turn on strobe.
- Make sure that the camera's flash is set to fire on every photo.
- Check that the fiber optic cord is attached.

Buttons are stuck

- Soak the housing in lukewarm fresh water. Depress each button several times while the housing is submerged.
- Apply lubricant to the button. Press the button several times to distribute the lubricant.

Button(s) or control(s) do not line up

- Ensure that nothing is preventing the camera from going into the housing.
- Push the camera mounting plate forward until it is flush with the housing base plate.

Camera is not functioning normally underwater

- Ensure that the camera mounting plate is pushed all of the way into the housing mounting plate.
- Check each housing control while underwater to ensure that they are disengaged. An inadvertently engaged control may limit functioning of the camera.
- Check that the zoom control is not engaged.

Backscatter or “snow” in images

- Position strobes or lights farther away from your lens and at a slight angle.
- Avoid using strobes in extremely low-visibility conditions.

Limited Warranty

This Ikelite product is warranted against any manufacturing defects for a period of two (2) years from the original date of purchase. Defective products should be returned to Ikelite postage paid. Ikelite will, at its sole discretion, repair or replace such products, and will return to customer postage paid. All other claims of any nature are not covered. Except as mentioned above, no other warranty expressed or implied applies to this Ikelite product.

Service and Repairs

Ikelite is most interested in performing any service to ensure that all products perform as intended. Evidence of purchase date must be provided to obtain warranty service.

No prior authorization is required. You may return directly to us or through your dealer. Please include a brief description of the problem, any relevant email correspondence, and/or description of the service request. Always include name, shipping address, email address, and phone number inside of the package. Send postage paid to:

Ikelite Underwater Systems
Attn: Service Department
50 West 33rd Street
Indianapolis, IN 46208 USA

For the separate international customs documentation form that you complete to accompany the shipment, please state or designate that the enclosed products were originally manufactured in the USA and are being returned to the manufacturer for repair service. Value of the equipment listed for customs purposes should be zero.

Contact Us

If you have any questions about your product or need advice on getting the images you want, please get in touch with us and we'll do everything we can to help you capture your unique perspective.

Ikelite Underwater Systems
50 W 33rd St
Indianapolis, IN 46208 USA
(317) 923-4523
ikelite@ikelite.com

